

Nilfisk Liberty SC60

Instructions for Use

Instructions for Use
Original Instructions
Instrucciones de uso

11/2020 revised 3/2021 REV B
Form no. 56091234



ecoflex™

A-English
B-Español

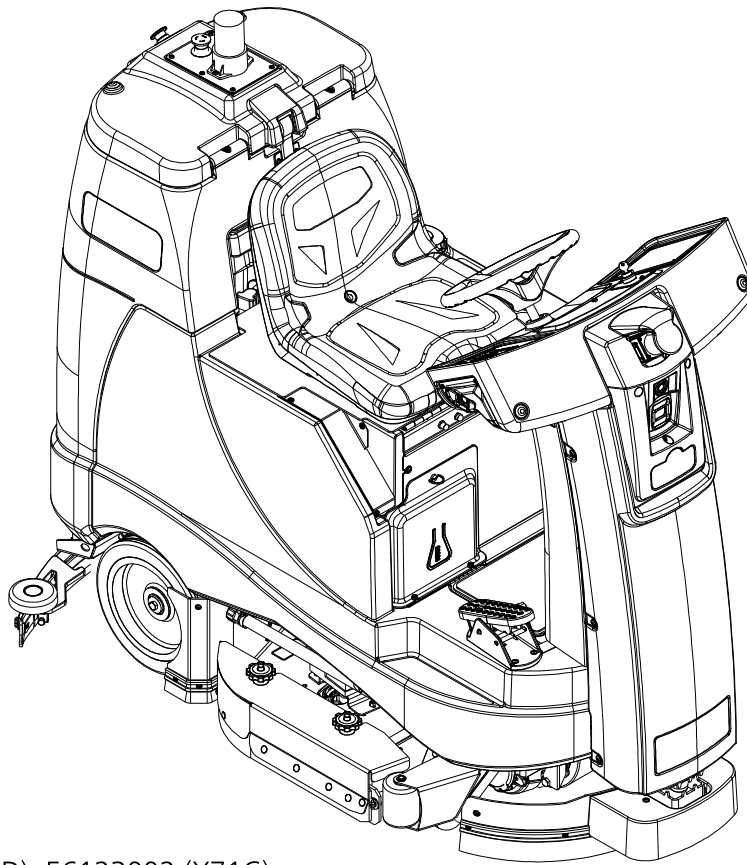

Model No:
56123000 (X71D), 56123002 (X71C)



WARNING:

The operation of this machine is strictly reserved to trained and qualified operators.



ADVERTENCIA:

El funcionamiento de esta máquina está estrictamente reservado a los operadores capacitados y calificados.

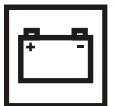

 **Nilfisk**

TABLE OF CONTENTS

Introduction.....	2	Operating the Machine.....	22
Parts and Service.....	3	Starting the Machine	22
Modifications	3	Pair a Mobile Device to ROC	24
Name Plate.....	3	Access the Learning Center	25
Uncrate the Machine	3	Stopping the Machine.....	26
Transporting the Machine.....	3	Teach Route for Autonomous Mode	27
Cautions and Warnings.....	4	Run Route, Autonomous Mode	33
Regulatory.....	7	Cancel Route.....	37
Know Your Machine.....	8	Delete Route	37
Control Panel.....	10	Operating the Machine Manual Mode	40
Autonomy Touchscreen.....	11	After Use	42
Autonomy Components.....	12	Maintenance.....	43
Prepare the Machine for Use.....	13	Maintenance Schedule.....	43
Batteries	13	Cleaning Recovery Tank	43
Install the Batteries.....	13	Cleaning Solution Filter	44
Home Marker.....	14	Clean Sensor Lenses	44
Install the BrushES (Disc System)	15	Lubricating the Machine	45
Automatic Brush Removal (Disc System)	15	Clean Drip Tubes & Solution Trough (Cylindrical System)	45
Install the Brushes (Cylindrical System).....	16	Electromagnetic Brake	45
FIGURE 2-5	16	Charging GEL/AGM (VRLA) Batteries	46
Install the Squeegee.....	17	Squeegee Maintenance	47
Fill the Solution Tank	17	Squeegee Adjustment	47
Detergent System Preparation (Ecoflex).....	18	Side Blade Maintenance	48
Detergent System Purge	19	Side Blade Height Adjustment.....	48
Detergent System Use (Ecoflex)	20	Troubleshooting	49
		General Machine Troubleshooting	49
		Tripping The Circuit Breakers.....	49
		Alert Display	50
		Specifications	51
		Accessories / Options.....	51
		Material Composition and Recyclability.....	51
		Solution Flow Rates	51
		Technical Specifications	52
		Glossary	53

INTRODUCTION

This manual will help you get the most from your Nilfisk Scrubber. Read it thoroughly before operating the machine.

Note: Bold numbers in parentheses indicate an item illustrated on pages 8 – 12.

This machine is intended for commercial use, for example in hotels, schools, factories, shops, offices and rental businesses. The Nilfisk Liberty SC60 is a battery powered floor cleaning machine.

WARNING:

The operation of this machine is strictly reserved to trained and qualified operators.

PARTS AND SERVICE

Repairs, when required, should be performed by Nilfisk, Inc., who employs factory trained service personnel, and maintains an inventory of Nilfisk original replacement parts and accessories.

Call NILFISK, INC. for repair parts or service. Please specify the Model and Serial Number when discussing your machine.

MODIFICATIONS

Modifications and additions to the cleaning machine which affect capacity and safe operation shall not be performed by the customer or user without prior written approval from Nilfisk, Inc. Unapproved modifications will void the machine warranty and make the customer liable for any resulting accidents.

NAME PLATE

The Model Number (also known as Part Number) and Serial Number of your machine are shown on the Nameplate, located on the bottom side of the seat panel.

Date of Manufacture "Date Code" is marked on the nameplate. Date Code: A20, means January 2020.

This information is needed when ordering repair parts for the machine. Use the space below to note the Model Number and Serial Number of your machine for future reference.

MODEL NO. _____

SERIAL NO. _____

UNCRATE THE MACHINE

When the machine is delivered, carefully inspect the shipping packaging and the machine for damage. If damage is evident, save the shipping carton (if applicable) so that it can be inspected. Contact the Nilfisk Customer Service Department immediately to file a freight damage claim. Refer to the unpacking instruction sheet included with the machine to remove the machine from the pallet.

WARNING!

The Products sold with this Manual contain or may contain chemicals that are known to certain governments (such as the State of California, as identified in its Proposition 65 Regulatory Warning Law) to cause cancer, birth defects or other reproductive harm. In certain locations (including the State of California) purchasers of these Products that place them in service at an employment job site or a publicly accessible space are required by regulation to make certain notices, warnings or disclosures regarding the chemicals that are or may be contained in the Products at or about such work sites. It is the purchaser's responsibility to know the content of, and to comply with, any laws and regulations relating to the use of these Products in such environments. The Manufacturer disclaims any responsibility to advise purchasers of any specific requirements that may be applicable to the use of the Products in such environments.

TRANSPORTING THE MACHINE

CAUTION!

Before transporting the machine in a closed truck or trailer, make sure that . . .

- All tanks are empty.
- If a ramp is required to load/unload the machine, remove Front Guard Assembly **(46)** prior to driving the machine up or down a ramp.
- Recovery tank cover secured in closed position.
- Scrub deck and squeegee are in the down position.
- The machine is tied down securely - see Tie Down Locations **(6)** in *Know Your Machine*. Only use locations designated as "Tie Down Locations" to secure the machine during transport. Using any other location of the machine to tie down the machine may cause damage or injury.
- The machine's electromagnetic brake is engaged (not manually overridden), see *Electromagnetic Brake* section if necessary.

CAUTIONS AND WARNINGS

SYMBOLS

Nilfisk uses the symbols below to signal potentially dangerous conditions. Always read this information carefully and take the necessary steps to protect personnel and property.

DANGER!

Is used to warn of immediate hazards that will cause severe personal injury or death.

WARNING!

Is used to call attention to a situation that could cause severe personal injury.

CAUTION!

Is used to call attention to a situation that could cause minor personal injury or damage to the machine or other property.



Read all instructions before using.

GENERAL SAFETY INSTRUCTIONS

Specific Cautions and Warnings are included to warn you of potential danger of machine damage or bodily harm. This machine is intended for commercial use, for example in hotels, schools, factories, shops, offices and rental businesses.

WARNING!

- The operation of this machine is strictly reserved to trained and qualified operators.
- This machine is not intended for use by persons (including children) with reduced physical, sensory or mental capabilities, or lack of experience and knowledge.
- While on ramps or inclines, avoid sudden stops. Avoid abrupt sharp turns. Use low speed down ramps.
- Observe the Gross Vehicle Weight, GVW, of the machine when loading, driving, lifting or supporting the machine.
- Keep sparks, flame and smoking materials away from batteries. Explosive gases are vented during normal operation.
- Charging the batteries produces highly explosive hydrogen gas. Charge batteries only in well-ventilated areas, away from open flame. Do not smoke while charging the batteries.
- Remove all jewelry when working near electrical components.
- Turn the machine power OFF and disconnect the batteries before servicing electrical components.
- Never work under a machine without safety blocks or stands to support the machine.
- Do not dispense flammable cleaning agents, operate the machine on or near these agents, or operate in areas where flammable liquids exist.

CAUTIONS AND WARNINGS - CONTINUED** WARNING!**

- Do not clean this machine with a pressure washer.
- Only use the brushes or pads provided with the appliance or those specified in the instruction manual. The use of other brushes or pads may impair safety.
- Do not operate the machine close to overhanging objects such as racking, ladders, wall hung fire extinguishers, tables and similar objects.
- Do not operate the machine in autonomous mode in the vicinity of elevated support platforms such as ladders, scaffolding, cherry pickers and similar items.

 CAUTION!

- This machine is not approved for use on public paths or roads.
- This machine is not suitable for picking up hazardous dust.
- Do not use scarifier discs and grinding stones. Use only pads or brushes intended for floor cleaning. Nilfisk will not be held responsible for any damage to floor surfaces caused by using the wrong or improper pads or brushes.
- When operating this machine, ensure that third parties, particularly children, are not endangered.
- Before performing any service function, carefully read all instructions pertaining to that service task.
- After use power the machine off at the key switch, do not leave the machine unattended where it can be accessed by others.
- Power the machine OFF at the key switch and remove the key, before changing the brushes, and before opening any access panels.
- Take precautions to prevent hair, jewelry, or loose clothing from becoming caught in moving parts.
- Use caution when moving this machine in below freezing temperature conditions. Any water in the solution, recovery or detergent cartridges or in the hose lines could freeze, causing damage to valves, pumps and fittings. Flush with low-temperature windshield washer fluid.

CAUTIONS AND WARNINGS - CONTINUED**⚠ CAUTION!**

- The batteries must be removed from the machine before the machine is scrapped. The disposal of the batteries should be safely done in accordance with your local environmental regulations.
- Do not use on surfaces having a gradient exceeding that marked on the machine.
- All doors and covers are to be positioned as indicated in the instruction manual before using the machine.
- **CAUTION** - This machine should only be used and stored indoors.
- Do not spray this machine with pressurized water.
- Only use locations designated as "Tie Down Locations" to secure the machine during transport. Using any other location of the machine to tie down the machine may cause damage or injury.
- Do not operate the machine in an environment exceeding 122°F (50°C).
- Do not operate the machine without the Rear Wheel Guards **(45)** and Front Guard Assembly **(46)** in place.
- Do not use the machine in autonomous mode around stairways, escalators or open elevator shafts, or into any area where there is a significant drop in elevation without guarding. Machine can re-route from a trained path. Serious machine damage may result if it falls down stairs, escalators, or open shafts. The machine cannot climb stairs. In autonomous mode, machine is designed for use only on level surfaces.
- Do not operate the machine on a grade outside that which is written on the nameplate.
- Do not carry passengers (any person who is not the operator) on any part of the machine.
- While driving the machine manually, it is the Operator's responsibility to avoid contact with obstacles and individuals. The machine will not avoid them in the manual operating mode. There are no autonomous safety functions operating in the manual mode.
- Do not operate the machine on wet floors or low friction/slippery surfaces (ice, oil, etc.).
- Do not operate the machine near other autonomous vehicles.
- Ensure daily and periodic safety checks are completed.
- Ensure that area to be scrubbed is clear of obstacles that are not fixed, such as hoses, buckets or pails, boxes, electrical cords, carts, pallets, etc.
- Do not hang anything from the 2D Drop-off LIDAR or any part of the machine.
- Do not operate autonomous function if the squeegee or water recovery system are not functioning correctly.
- Do not operate around unguarded bodies of water.
- Some objects could be difficult for the machine to detect, such as reflective black surfaces, other highly polished or reflective surfaces, or plexiglass. Avoid cleaning in autonomous mode in areas where these objects are present.
- Avoid use in environments where stopping could result in a safety risk, such as blocking an emergency exit or access to medical equipment.
- Children should be supervised to ensure that they do not play with the appliance.
- In order to prevent unauthorized use of the machine, the power source shall be switched off or locked, and key switch removed.
- Machines left unattended shall be secured against unintentional movement.

SAVE THESE INSTRUCTIONS

REGULATORY

This product contains radio equipment operating in the frequency bands and with max TX power as indicated below:

Frequency range [MHz]	Max TX pwr [dBm]
1920-1980 1710-1785 2500-2570 880-915 832-862	24
1920-1980 1710-1785 2500-2570 880-915 832-862 703-748	23

This product contains the chemical DOTE (2-ethyihexyl 10-ethyl-4,4-dioctyl-7-oxo-8-oxa-3,5-dithia-4-stannatetradecanoate; CAS number: 15571-58-1) which is listed on the candidate list of the EU REACH Regulation (1907/2006/EC).

KNOW YOUR MACHINE

As you read this manual, you will occasionally run across a bold number or letter in parentheses - example: **(2)**. These numbers refer to an item shown on these pages unless otherwise noted. Refer back to these pages whenever necessary to pinpoint the location of an item mentioned in the text. **NOTE:** Refer to the service manual for detailed explanations of each item illustrated on the next 4 pages.

- | | |
|----------------------------------------|--------------------------------------------------|
| 1 Operator's Seat | 12 Detergent Cartridge Access Cover |
| 2 Solution Tank Drain Hose | 13 Detergent Cartridge |
| 3 Drive Pedal | 14 2D Drop-Off LIDAR |
| 4 Drive Wheel | 15 Side Blade Assembly Removal Knobs |
| 5 Circuit Breakers | 16 Electrical Compartment Access Door |
| 5a VIB (Vehicle Interface Board) 5 Amp | 17 Seat Adjustment Knob |
| 5b BCM (Brain Control Module) 10 Amp | 18 LIDAR Cover (NOT a lifting or tie down point) |
| 5c Steering 15 Amp | 19 Side Blade Assembly Height Adjustment Knobs |
| 6 Tie Down Locations (2 front) | 20 Front Roller Bumper |
| 7 Emergency Stop | 21 Beacon |
| 8 Scrub Deck | 22 2D Mapping LIDAR |
| 9 Steering Wheel | 23 2D Mapping LIDAR Guard |
| 10 Battery Compartment (under seat) | 24 Hour meter |
| 11 Squeegee Assembly | 25 Turn Signal |

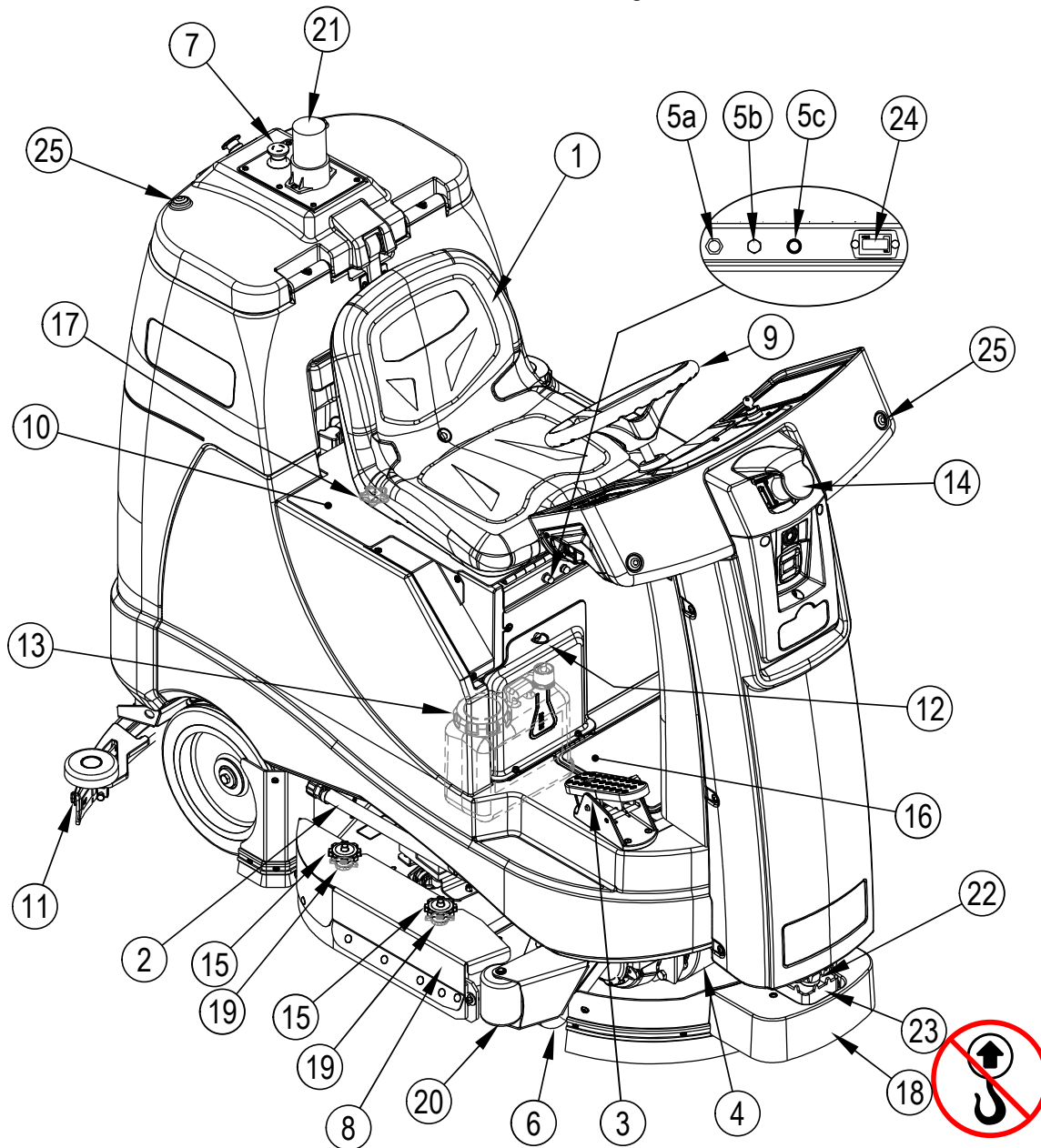

KNOW YOUR MACHINE

- | | | | |
|----|------------------------------|----|-----------------------------------|
| 6 | Tie Down Location (2 rear) | 36 | Recovery Tank Drain Hose |
| 7 | Emergency Stop | 37 | Rear Squeegee Blade Removal Latch |
| 25 | Turn Signal | 38 | Squeegee Removal Knobs |
| 26 | Autonomy Touchscreen Display | 39 | Machine Battery Connector |
| 27 | Key Switch | 40 | Solution Tank Fill Cap |
| 28 | Control Panel | 41 | Solution Shutoff Valve |
| 29 | Recovery Tank Cover | 42 | Solution Filter |
| 30 | Home Marker | 43 | Solution Solenoid |
| 31 | Vacuum Motor Filter Housing | 44 | Solution Pump |
| 32 | Debris Catch Tray | 45 | Rear Wheel Guards |
| 33 | Start/Pause Button | 46 | Front Guard Assembly |
| 34 | Recovery Hose | 47 | Hopper (Cylindrical only) |
| 35 | Squeegee Tilt Adjust Knob | | |

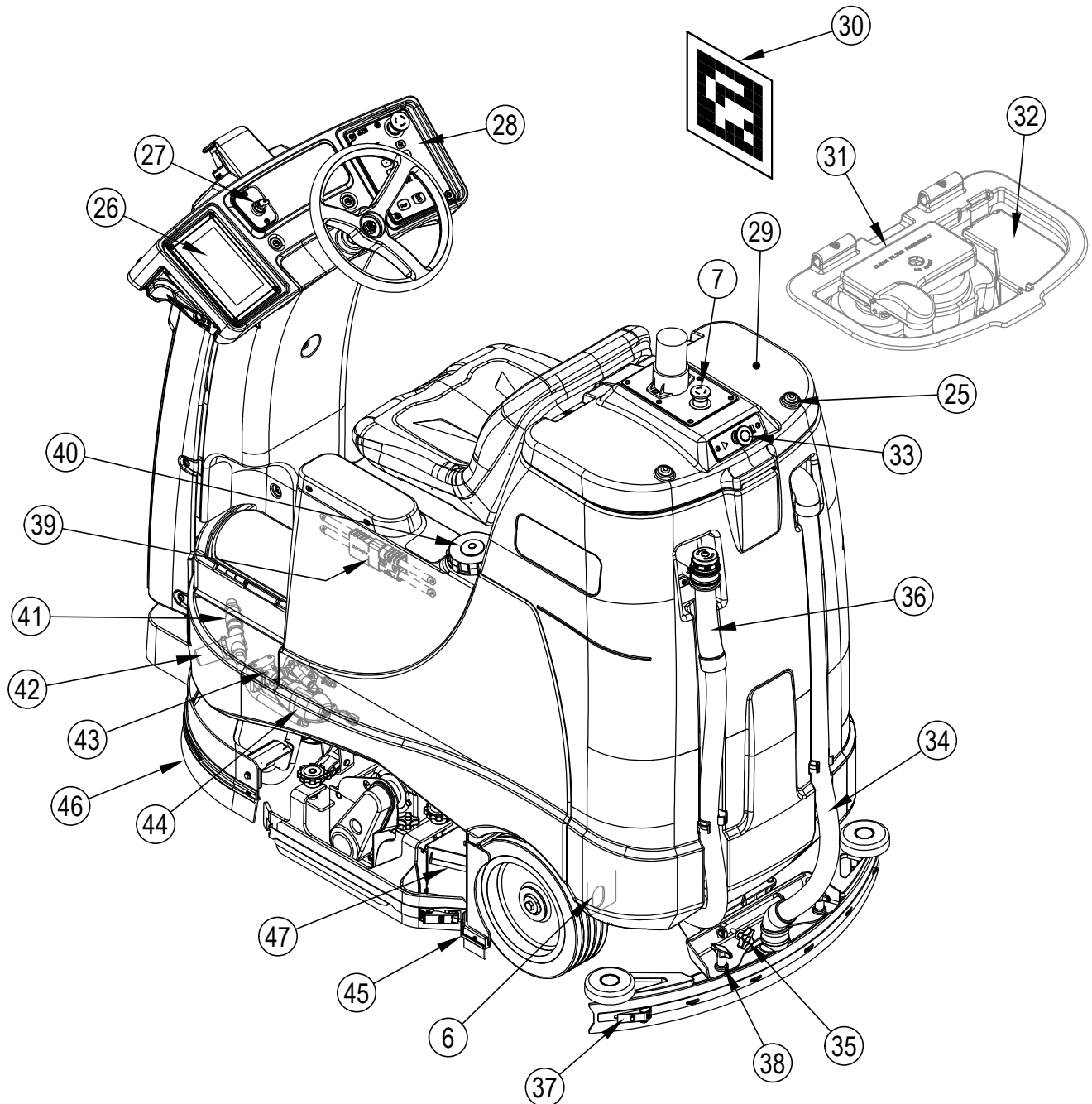

CONTROL PANEL

A- Scrub Pressure Decrease Switch

A+ Scrub Pressure Increase Switch

A1 Scrub Pressure Indicators

- FIRST = Regular
- SECOND = Heavy
- THIRD = Extreme
- NONE = Off

B- Solution Flow Decrease Switch

B+ Solution Flow Increase Switch

B1 Solution Flow Indicators

- FIRST = Low
- SECOND = Medium
- THIRD = High
- NONE = Off

C- Detergent Mode Decrease Switch

C+ Detergent Mode Increase Switch

C1 Detergent Mode Indicators

- FIRST = Detergent Low Mode
- SECOND = Detergent Medium Mode
- THIRD = Detergent High Mode
- NONE = Off

D Burst of Power Switch

D1 Burst of Power Indicator

E Emergency Stop

F Vacuum Switch

F1 Vacuum On Indicator

K Horn Switch

L Reverse Drive Switch

L1 Reverse Drive Indicator

M One-Touch™ Scrub ON/OFF Switch

M1 Scrub On Indicator

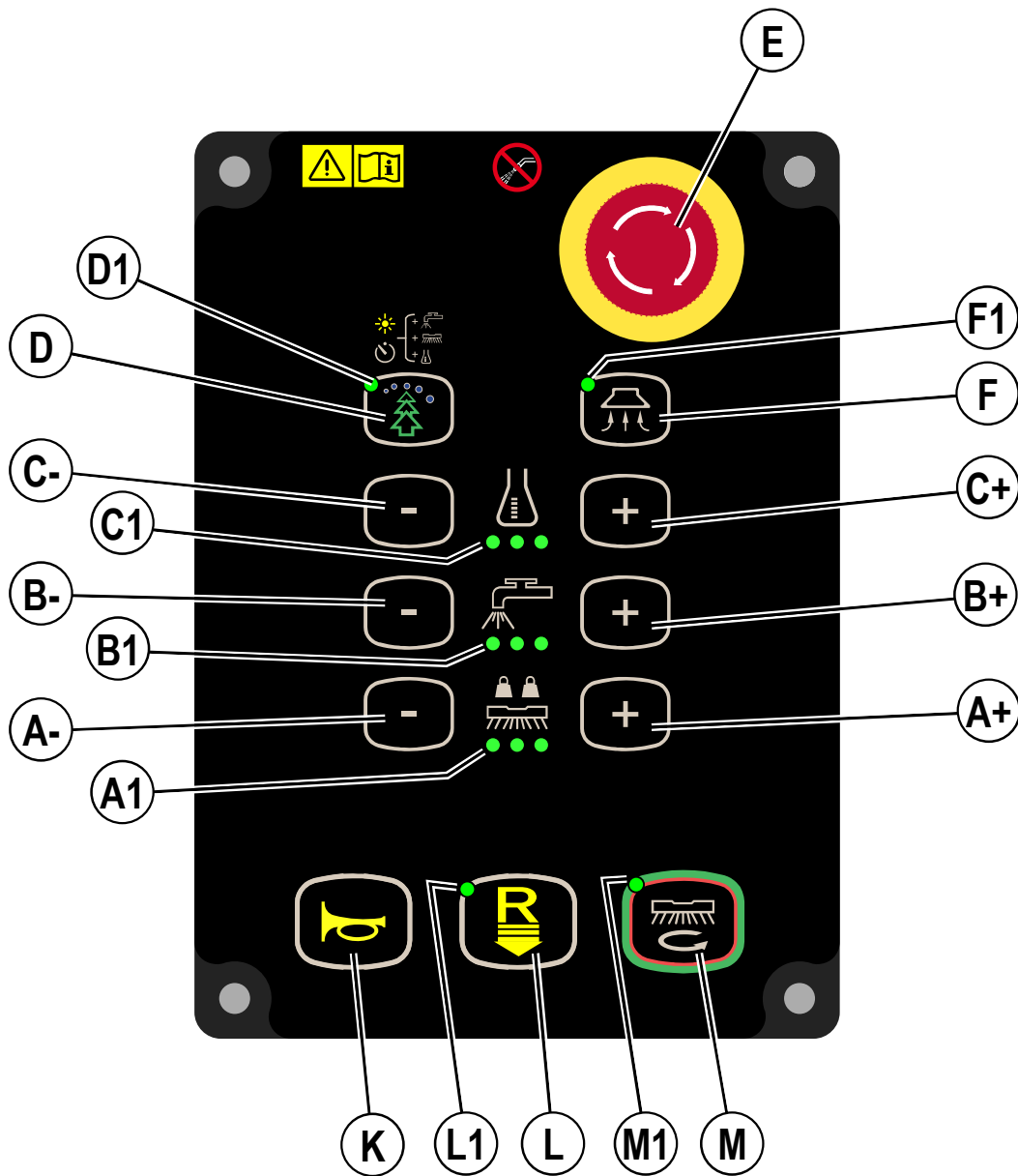

AUTONOMY TOUCHSCREEN

- N Clock
- O Battery Indicator
- P ROC (Robotic Operations Center) Connection Status
- Q Notifications

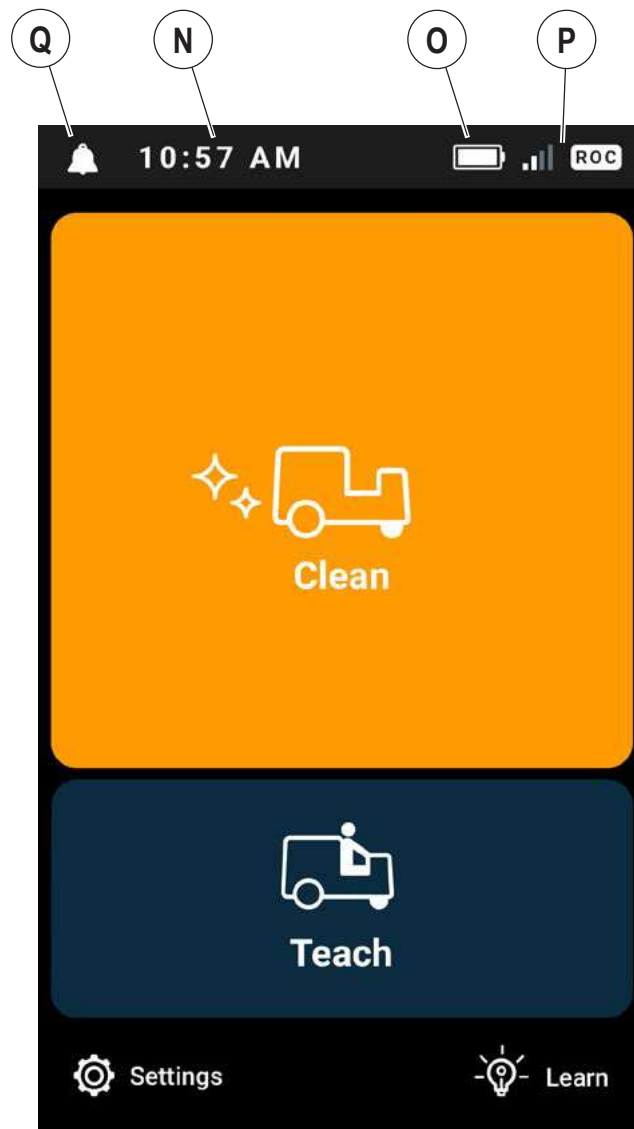

AUTONOMY COMPONENTS

The Nilfisk Liberty SC60 can function autonomously meaning that it functions (operates) on its own, on a route determined by an operator without further operator involvement. The machine can be taught an area to clean independently and actively maneuver around certain obstacles.

Components that make up the Autonomy system, and their basic function, include the following (shown in Figure 1-1):

- **BrainOS Software Platform (not shown).** Enables machines to navigate complex environments by accessing sensors to scan environment.
- 14 2D Drop-Off LIDAR** - Drop-off Laser, detects drop-offs, or major changes in floor elevation
- 22 2D Mapping LIDAR** - Mapping Laser, provides detection of obstacles in front of the machine
- 50 Front 2D Environment Camera** - provides an image of the area in front of the machine
- 51 Front 3D Obstacle Camera** - provides a three-dimensional image of the area in front of the machine
- 52 2D Environment Camera (Left and Right)** - provides an image of the areas to the left and right of the machine
- 53 3D Obstacle Camera (Left and Right)** - provides a three-dimensional image of the areas to the left and right of the machine

FIGURE 1-1

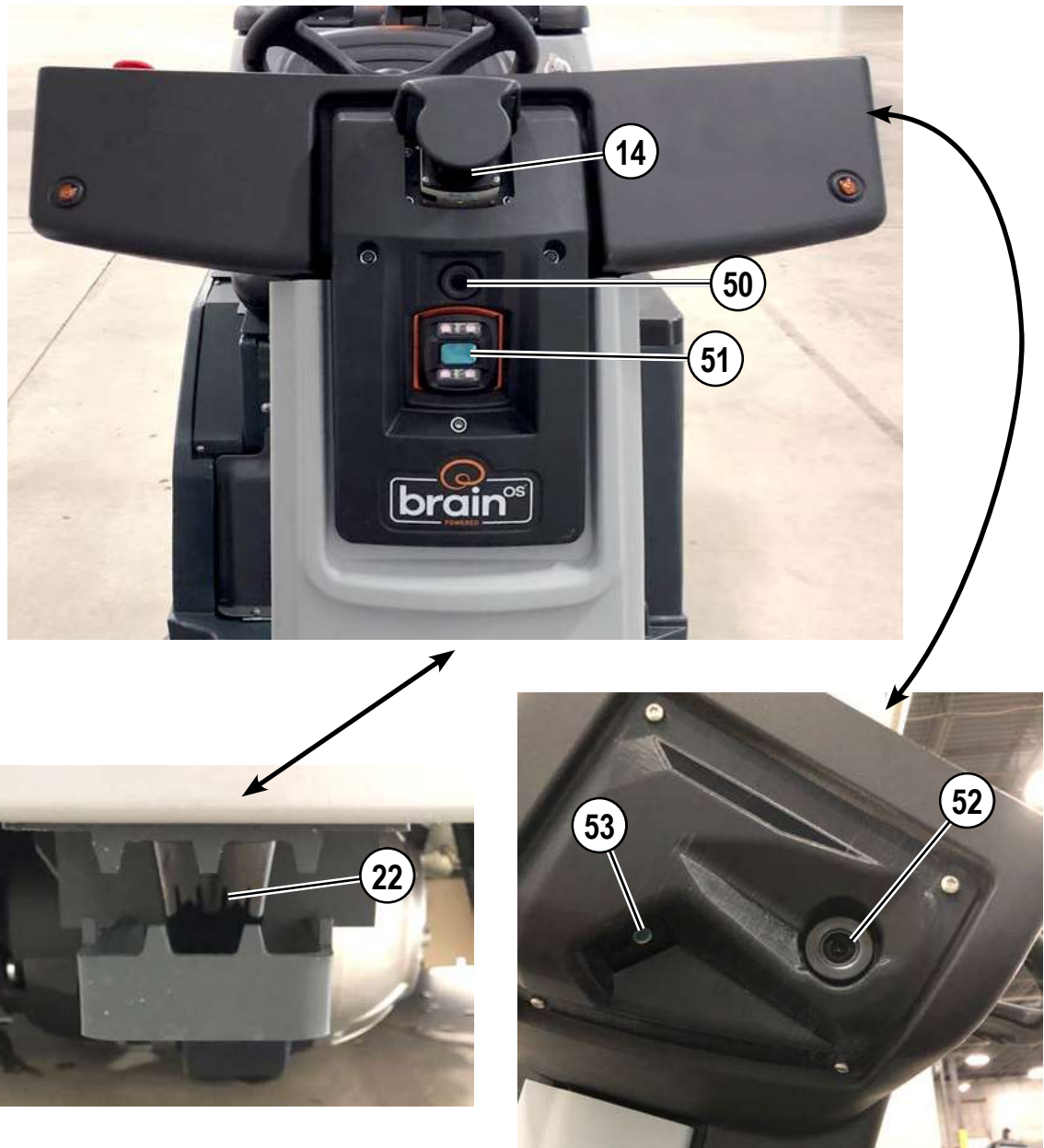

PREPARE THE MACHINE FOR USE

BATTERIES

If this machine shipped with batteries installed do the following:

- Check that the batteries are connected to the machine (39).
- Turn ON the Key Switch (27) to power ON machine and check the Battery Indicator (O). If the gauge is completely filled the batteries are ready for use. If the gauge is less than full the batteries should be charged before use. See the "Charging the Batteries" section.
- **IMPORTANT!** REFER TO THE BATTERY CHARGER'S OEM PRODUCT MANUAL FOR INSTRUCTIONS REGARDING SETTING THE CHARGER FOR BATTERY TYPE.

If this machine shipped without batteries installed do the following:

- Consult an Authorized Nilfisk dealer for recommended batteries.
- Install the batteries by following the instructions below.
- **IMPORTANT!** REFER TO THE BATTERY CHARGER'S OEM PRODUCT MANUAL FOR INSTRUCTIONS REGARDING SETTING THE CHARGER FOR BATTERY TYPE.

INSTALL THE BATTERIES

⚠ WARNING !

Use extreme caution when working with batteries. Sulfuric acid in batteries can cause severe injury if allowed to contact the skin or eyes. Explosive hydrogen gas is vented from inside the batteries through openings in the battery caps. This gas can be ignited by any electrical arc, spark or flame. If battery acid makes contact with your skin or eyes, flush the affected area with water for 5 minutes and seek medical attention.

When Servicing Batteries...

- Remove all jewelry to avoid accidental shorts.
- Do not smoke.
- Wear safety glasses, a rubber apron and rubber gloves.
- Work in a well-ventilated area.
- Do not allow tools to touch more than one battery terminal at a time.
- ALWAYS disconnect the negative (ground) cable first when replacing batteries to prevent sparks.
- ALWAYS connect the negative cable last when installing batteries.

⚠ CAUTION !

Electrical components in this machine can be severely damaged if the batteries are not installed and connected properly. Batteries should be installed by Nilfisk or by a qualified electrician.

Only batteries approved for use in this machine by Nilfisk shall be installed.

- 1 Remove the batteries from their shipping crate and carefully inspect them for cracks or other damage. If damage is evident, contact the carrier that delivered them or the battery manufacturer to file a damage claim.
- 2 Turn the Key Switch (27) off (O) and remove the key.
- 3 Tip the seat forward to open the Battery Compartment (10) and set the prop rod.
- 4 Using (2) people and an appropriate lifting strap, carefully lift the batteries into the compartment tray exactly as shown. Refer to the battery wiring decal 56123085 on the underside of the seat panel.
- 5 **See Figure 2-1.** Install battery cables as shown and carefully tighten the nut in each battery terminal until the battery cable will not rotate. Do not over-tighten the terminals, or they will be very difficult to remove for future service.
- 6 Install the battery boots and secure tightly to the battery cables with the supplied tie straps.
- 7 Connect the battery pack connector to the Machine Battery Connector (39) and close the battery compartment cover.

When changing batteries or the charger, please contact a local authorized service center for correct battery, charger and machine settings to prevent battery damage.

FIGURE 2-1

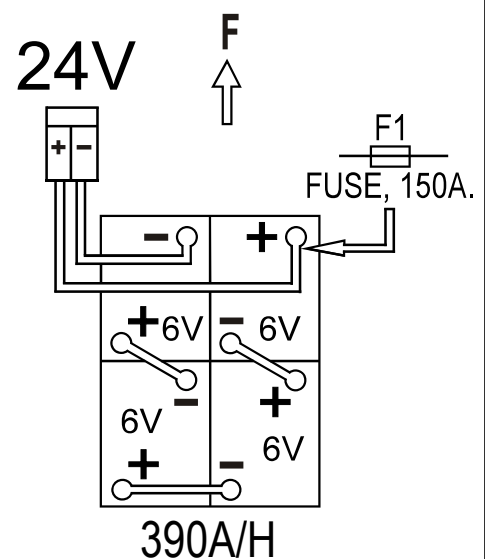

HOME MARKER

Home Markers must be permanently installed before the machine can operate in autonomous mode. The Home Marker is a QR type code that the machine scans to identify its current location and associates saved routes to each unique home marker.

Home Markers are used to establish the start and end points of a cleaning route. The number of Home Markers required depends on the size of the space in which the machine operates in autonomous mode.

The machine uses a Home Marker (30) to identify its specific position within the building see **Figure 2-2**.

- 1 The Home Marker should be mounted permanently on a wall or fixed flat object near commonly cleaned areas that do not change from day-to-day. If the Home Marker is moved even slightly, the route might not be followed correctly.
- 2 Machine needs an unobstructed view of the Home Marker from the right 2D camera.
- 3 Home Marker needs to be in a well-lit area for machine to scan.
- 4 Do not install Home Markers near stairways, fire exits, or fire, first aid, or emergency equipment.
- 5 Mount the Home Marker at a height of 40 inches (100 cm) from the floor.
- 6 The top edge of the Home Marker must be level with the floor.
- 7 After mounting the Home Marker, remove the protective film from its face. The Home Marker is supplied with a microfiber cloth for keeping it clean.
- 8 Do not photocopy, laminate, or place a Home Marker in a glossy sleeve or cover, this could prevent the machine from being able to scan the Home Marker.
- 9 The machine can use up to 10 different Home Markers with 6 saved routes per Home Marker for 60 total routes possible.
- 10 Install a unique Home Marker for each floor of a multilevel building.
- 11 If a Home Marker is lost or damaged, contact customer service for a replacement.
- 12 QR type codes used as "Location Tags" for other Nilfisk autonomous machines are not compatible with Liberty SC60.

When scanning a Home Marker, drive the machine so that the right side of the machine is;

- 1 Parallel to the wall to properly read the Home Marker.
- 2 A distance of no less than 24 inches (61 cm).

IMPORTANT! Prior to teaching any routes the Home Marker has to be installed and identified by the machine.

FIGURE 2-2

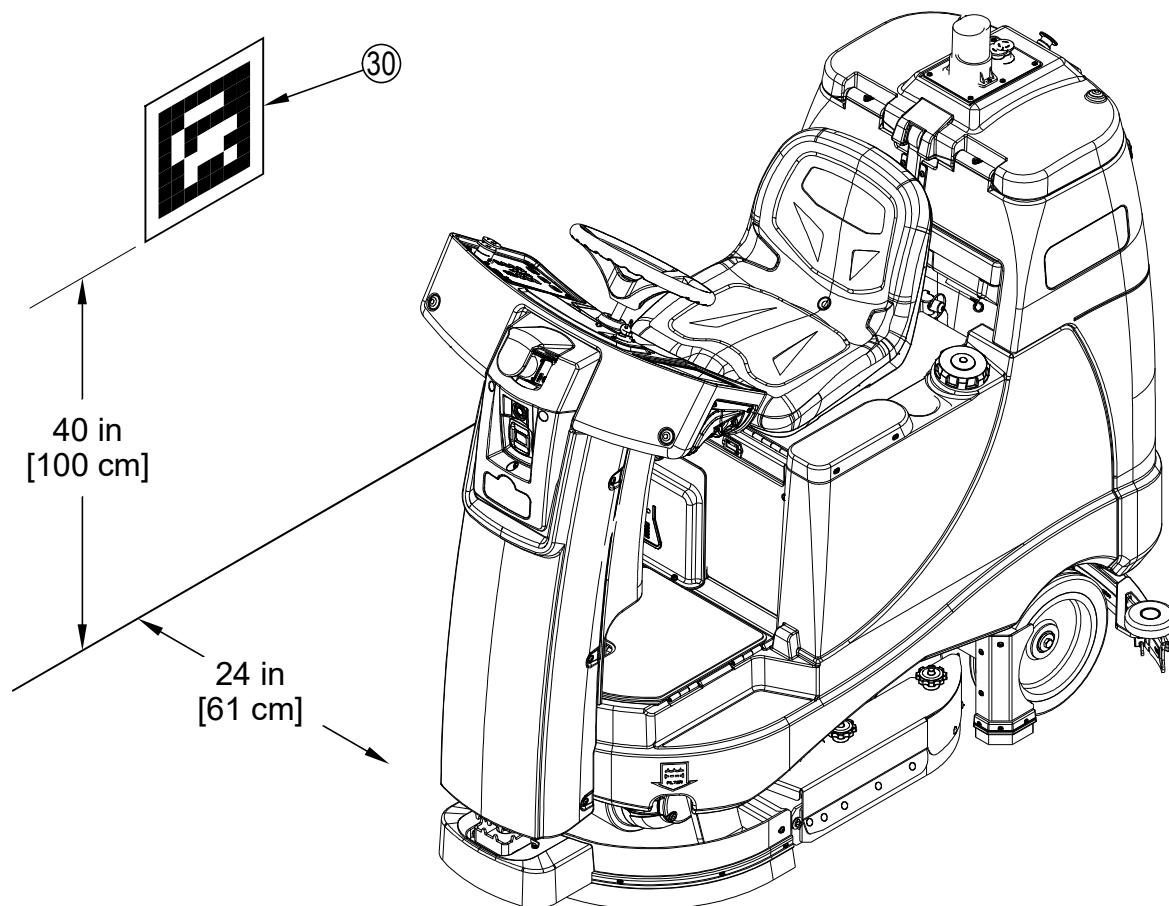

INSTALL THE BRUSHES (DISC SYSTEM)

- 1 Verify which brush or pad is appropriate for the floor surface to be cleaned.
- 2 Make sure the Scrub Deck (8) is in the RAISED position. Make sure the Key Switch (27) is off.

⚠ CAUTION !

Turn the key switch off (O) and remove the key, before changing the brushes, and before opening any access panels.

- 1 Make sure the Scrub Deck is in the RAISED position. Make sure the Key Switch (27) is in the OFF position (O).
- 2 **See Figure 2-4.** Remove both side blade assemblies. **NOTE:** The blade assemblies are held in place by two large Knobs (AA). Loosen these knobs and slide the Side Blade Assemblies (AB) slightly forward and then off the Scrub Deck.
- 3 To install the Brushes (AC) (or pad holders) align the Lugs (AD) on the brush with the holes on the mounting plate and turn to lock in place (turn the outside edge of brush towards the front of machine as shown by arrow (AE)). **NOTE:** While scrubbing the brushes rotate in the direction as shown by arrow (AF).

FIGURE 2-4

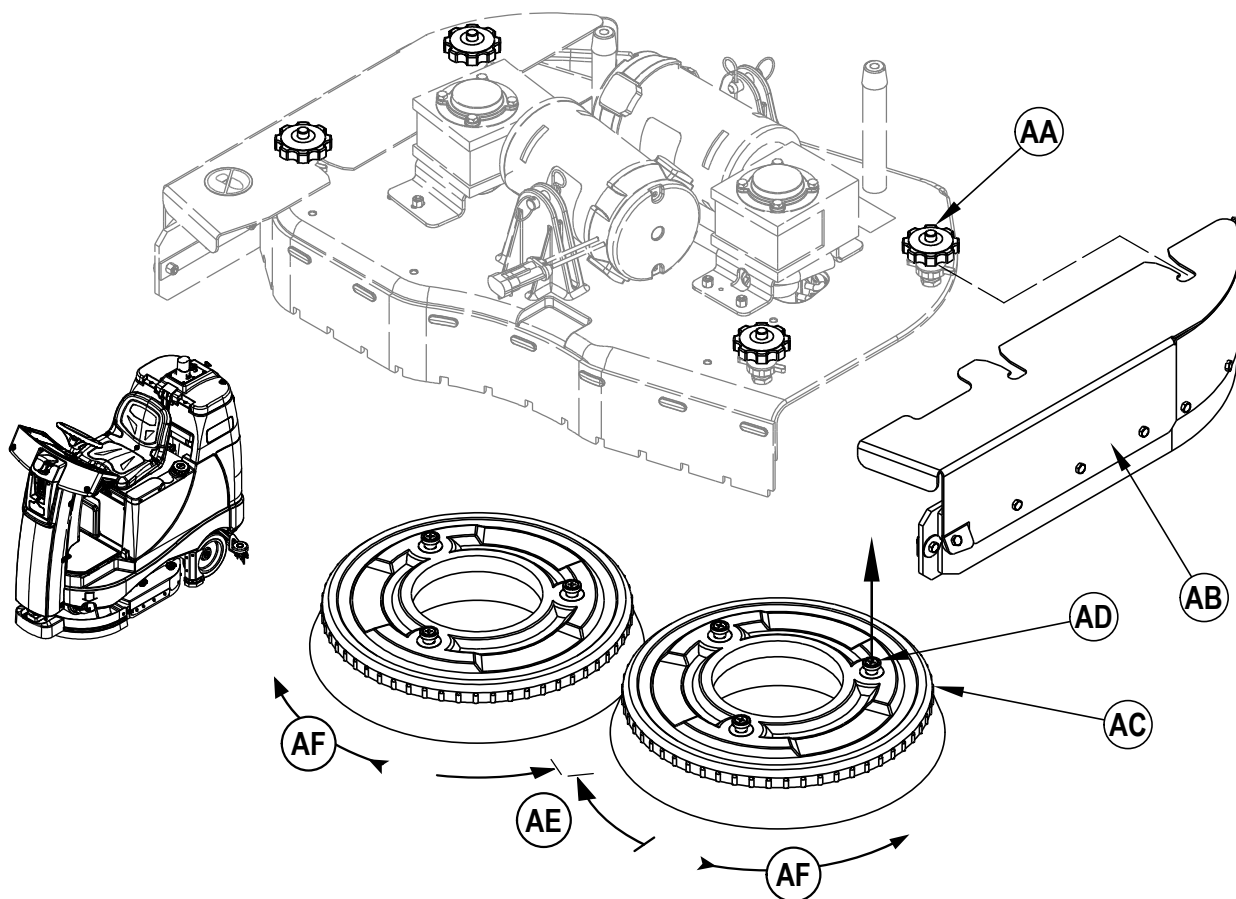

AUTOMATIC BRUSH REMOVAL (DISC SYSTEM)

- 1 Turn the Key Switch (27) to the ON position (I). Wait for initial start up screen.
- 2 Make sure the Scrub Deck (8) is in the RAISED position.
- 3 Press and hold both Scrub Pressure Decrease Switch (A-) and Scrub Pressure Increase Switch (A+) for 3 seconds.
- 4 Brushes will begin to spin then stop abruptly and drop off of the scrub deck.

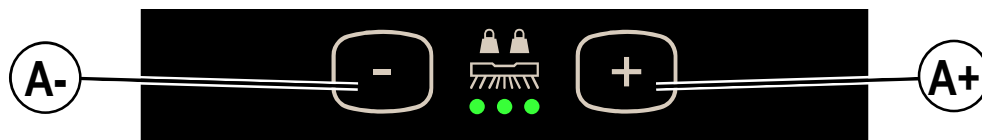

INSTALL THE BRUSHES (CYLINDRICAL SYSTEM)

- 1 Verify which brush or pad is appropriate for the floor surface to be cleaned.
- 2 Make sure the Scrub Deck (8) is in the RAISED position. Make sure the Key Switch (27) is off.

⚠ CAUTION !

Turn the key switch off (O) and remove the key, before changing the brushes, and before opening any access panels.

- 1 Make sure the Scrub Deck is in the RAISED position. Make sure the Key Switch (27) is in the OFF position (O).
- 2 **See Figure 2-5.** Remove both side blade assemblies. **NOTE:** The blade assemblies are held in place by Side Blade Assembly Removal Knobs (15). Loosen these knobs and slide the Side Blade Assemblies (BA) slightly forward and then off the Scrub Deck.
- 3 Loosen the Knobs (BB) on top of the Idler Assemblies (BC) and remove the assembly.
- 4 Slide the Brush (BD) into the deck housing, lift slightly, push and turn until it seats. Re-install the Idler Assemblies (BC) and Side Blade Assemblies (BA).

FIGURE 2-5

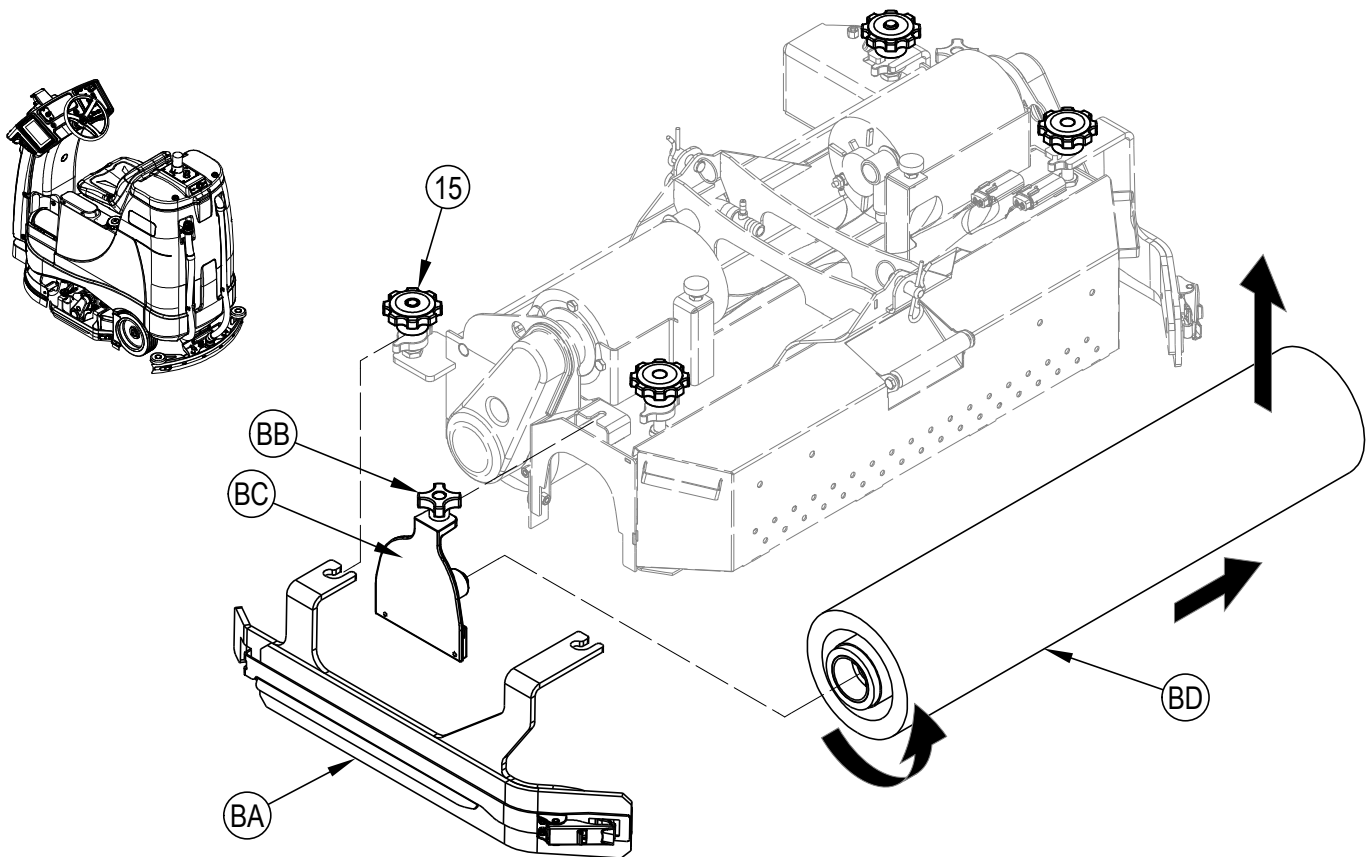

INSTALL THE SQUEEGEE

- 1 See Figure 2-6. Slide the Squeegee Assembly (11) onto the squeegee mount bracket and tighten the Squeegee Removal Knobs (38).
- 2 Connect the Recovery Hose (34) to the squeegee inlet.
- 3 Lower the squeegee, move the machine ahead slightly and adjust the squeegee tilt and height using the Squeegee Tilt Adjust Knob (35) and Squeegee Height Wheel (AC) so that the rear squeegee blade touches the floor evenly across its entire width and is bent over slightly as shown in the squeegee cross section.

FIGURE 2-6

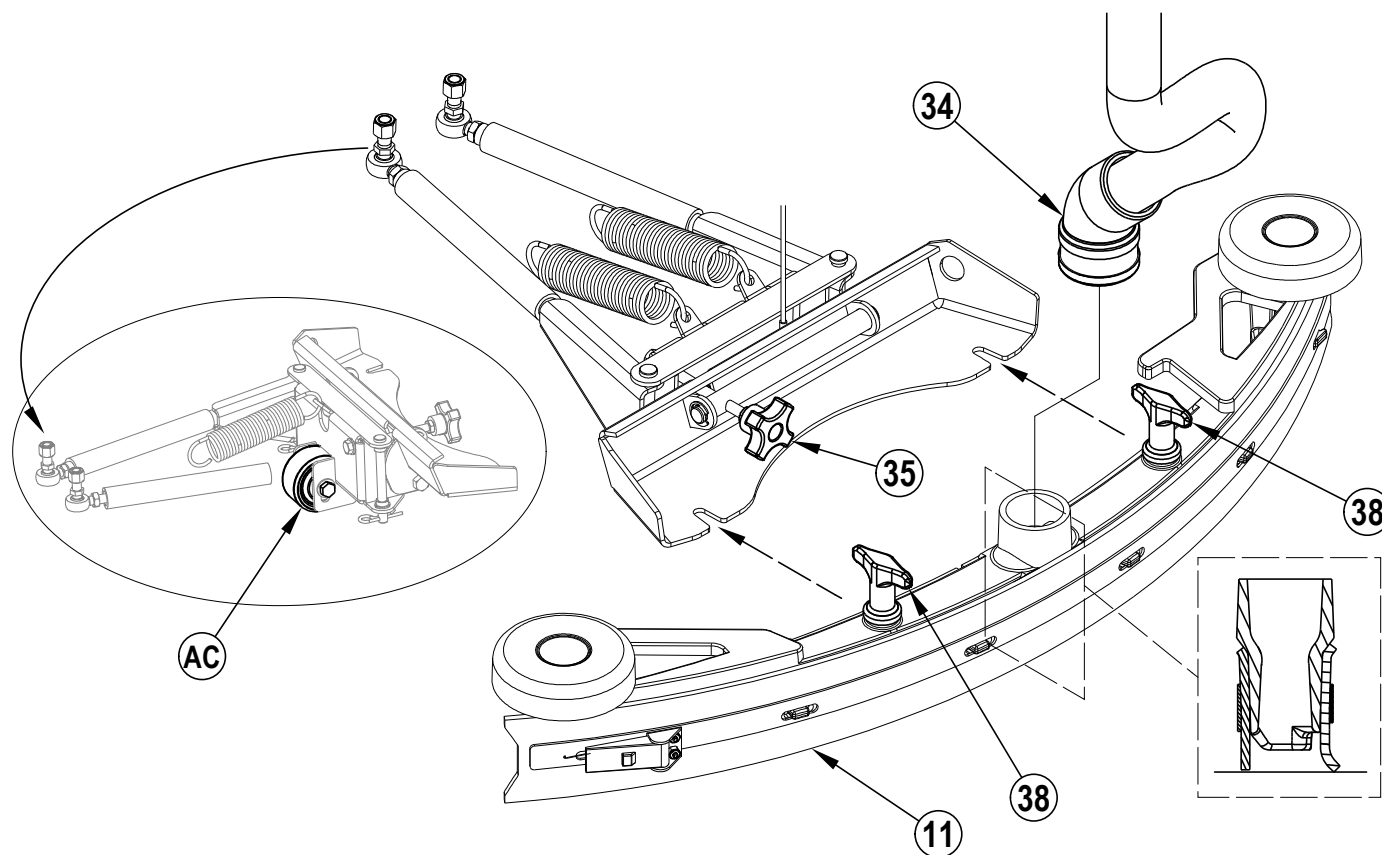

FILL THE SOLUTION TANK

Open the Solution Tank Fill Cap (40) then fill the tank with a maximum of 26 US gallons (100 liters) of cleaning solution.

The machine is equipped with EcoFlex - a detergent dispensing system. When using this system the solution tank should be filled with plain water. The machine can also be used conventionally with detergent mixed with water in the tank. Always follow the dilution instructions on the detergent container label. The solution should be a mixture of water and the proper cleaning detergent for the job.

CAUTION!

Use only low-foaming, non-flammable liquid detergents intended for automatic scrubber machine applications. Water temperature should not exceed 130 degrees Fahrenheit (55 degrees Celsius).

NOTE: When refilling the solution tank always empty the recovery tank using Recovery Tank Drain Hose (36).

DETERGENT SYSTEM PREPARATION (ECOFLEX)

FILL THE DETERGENT CARTRIDGE

CAUTION!

Always follow the instructions on the labels of the detergent cartridge when using floor cleaning detergents. Wear the appropriate personal protective equipment such as gloves and eye protection when handling floor cleaning detergents.

In the event of a detergent spill follow these four steps:

- Communicate the hazard. Immediately notify others working in the area and any supervisory personnel of the hazard, and if the situation warrants it, evacuate the area.
- Control the spill. Ensure the spill does not become any worse.
- Contain the hazard.
- Clean up the spill and any damage safely.

The Detergent Cartridge (13) is located behind the Detergent Cartridge Access Door (12) in the operator's compartment. Fill the detergent cartridge with a maximum of 1.25 gallons (4.73 Liters) of detergent. **SERVICE NOTE:** Remove the detergent cartridge from the detergent box prior to filling to avoid spilling detergent on the machine.

It is recommended that a separate cartridge be used for each detergent you plan to use. The detergent cartridges have a white decal on them so you can write the detergent name on each cartridge for clarification. When installing a new cartridge, remove the Factory Cap (AA) and place the cartridge in the machine. Install the Dry Break Cap (BB) and detergent hose as shown in **Figure 2-8**.

The system should be purged of previous detergent when switching to a different detergent (see "To Purge When Changing Detergent").

FIGURE 2-8

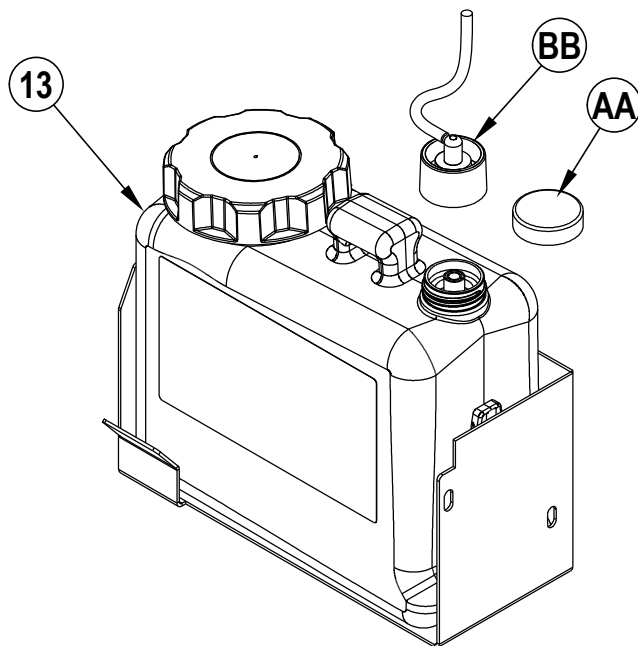

DETERGENT SYSTEM PURGE

To Purge When Changing Detergent (SCRUB AND SOLUTION SYSTEMS MUST BE OFF):

SERVICE NOTE: Move machine over floor drain before purging because a small amount of detergent will be dispensed in the process.

- 1 Disconnect and remove the detergent cartridge.
- 2 Turn the Key Switch (27) to ON (I) to power on the machine. Wait a few seconds for the start-up sequence to finish.
- 3 Press and hold the Detergent Mode Increase Switch (C+) and the Solution Flow Increase Switch (B+) down for 2 seconds. **NOTE:** Once activated the purge process takes 20 seconds. Press (C+) and (B+) again before 20 seconds to cancel purge. Normally one purge cycle is adequate to purge the system.

To Purge Weekly (SCRUB AND SOLUTION SYSTEMS MUST BE OFF):

- 1 Disconnect and remove the detergent cartridge. Install and connect a Cartridge filled with clean warm water.
- 2 Follow steps 2 and 3 from "To Purge When Changing Detergent".

When the detergent level is nearing the bottom of the cartridge it is time to refill or replace the cartridge.

SERVICE NOTE: Follow the "To Purge Weekly" instructions above if the machine is going to be stored for an extended period of time.

FIGURE 2-9

Purge

Press and hold (C+) & (B+) for 2 seconds to purge.

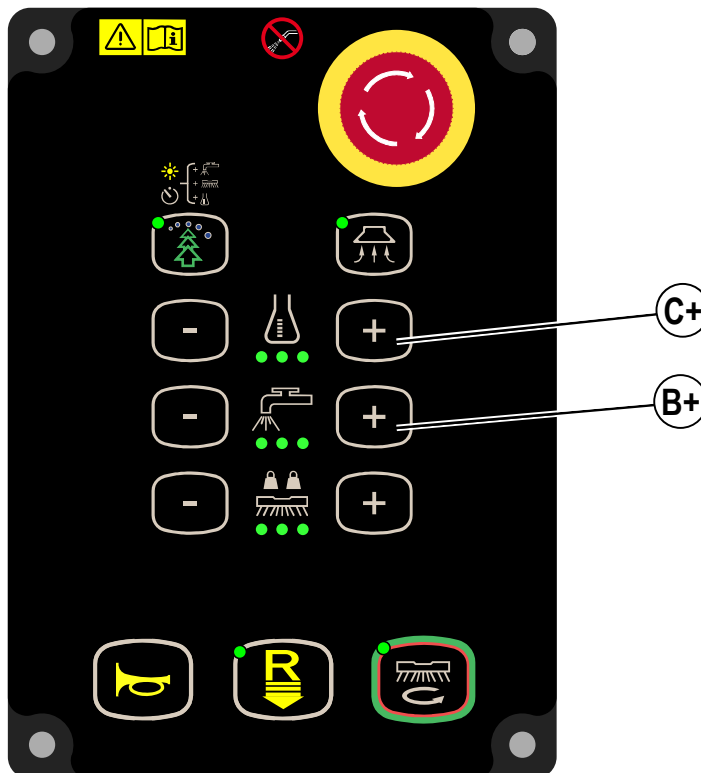

DETERGENT SYSTEM USE (ECOFLEX)

Detergent Ratio (**SCRUB AND SOLUTION SYSTEM MUST BE ON**):

No detergent is dispensed until the scrub and detergent systems are activated, direction is set to forward (Reverse Indicator (**L1**) not lit), and the Drive Pedal (**3**) is pressed.

- The Detergent Mode Indicators (**C1**) will light up when the detergent system is on.
- The three lights signify the selected ratio/percentage of detergent.

There are 5 modes of EcoFlex operation:

1. *Chemical Free Cleaning Mode* - During scrubbing, the detergent system can be turned off at any time by pressing the Detergent Mode Decrease Switch (**C-**) until all Indicators (**C1**) are off, to allow scrubbing with water only.
2. *Detergent Low Mode* – Activated by pressing the Detergent Mode Increase Switch (**C+**) when detergent is off (repeated presses will increase to Medium Mode and High Mode, press Decrease Switch (**C-**) to return to low mode).
 - The first Detergent Mode Indicator (**C1**) will be lit.
 - **Detergent = 0.3% / 3 ml/Liter / 1:300 Ratio**
3. *Detergent Medium Mode* – Activated by pressing the Detergent Mode Increase Switch (**C+**) when detergent is in Low Mode (additional presses will increase to High Mode, press Decrease Switch (**C-**) to return to medium mode).
 - The first and second Detergent Mode Indicators (**C1**) will be lit.
 - **Detergent = 1.0% / 10 ml/Liter / 1:100 Ratio**
4. *Detergent High Mode* – Activated by pressing the Detergent Mode Increase Switch (**C+**) when detergent is in Medium Mode (pressing Decrease Switch (**C-**) will decrease mode to medium then low).
 - All three Detergent Mode Indicators (**C1**) will be lit.
 - **Detergent = 3.0% / 30 ml/Liter / 1:32 Ratio**
5. *Burst of Power Cleaning Mode* – Press the Burst of Power Switch (**D**) to enter Burst of Power mode. Burst of Power Indicator (**D1**) will blink for one minute. Press Switch (**D**) again before 60 seconds to cancel Burst of Power.
 - Detergent ratio will increase to the next higher concentration detergent level. Detergent system will be turned ON at “detergent low mode” if it was OFF.
 - Solution flow rate will increase to the next higher level, visible at (**B1**).
 - Scrub pressure will increase to the next level, visible at (**A1**).
 - Vacuum power will have no change. If the vacuum system is off then it will remain off.

Once set, the detergent flow rate automatically increases and decreases with the solution flow rate, but the detergent ratio/percentage remains the same.

DETERGENT SYSTEM PREPARATION AND USE (ECOFLEX)

FIGURE 2-10

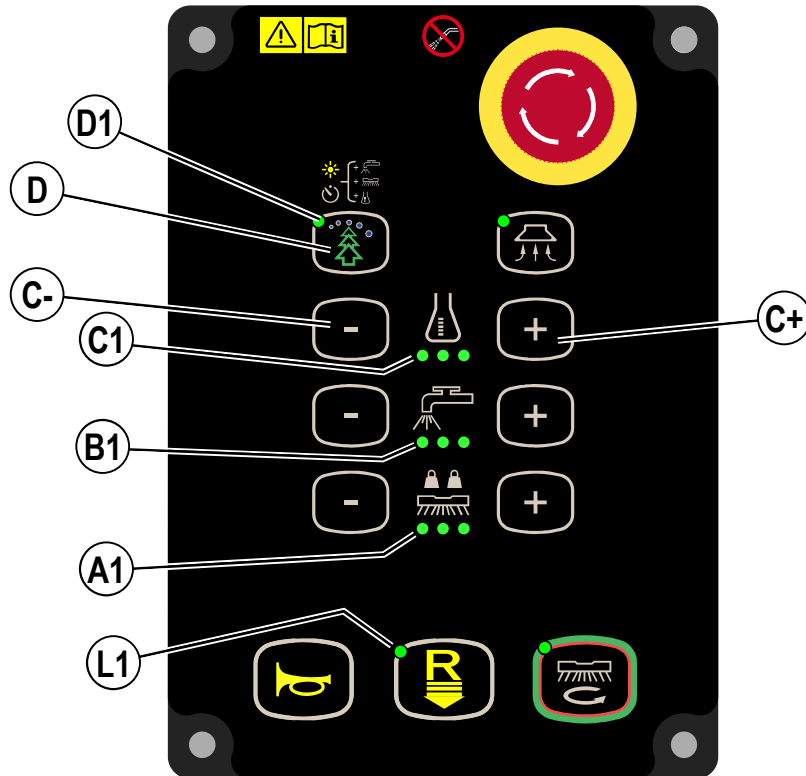
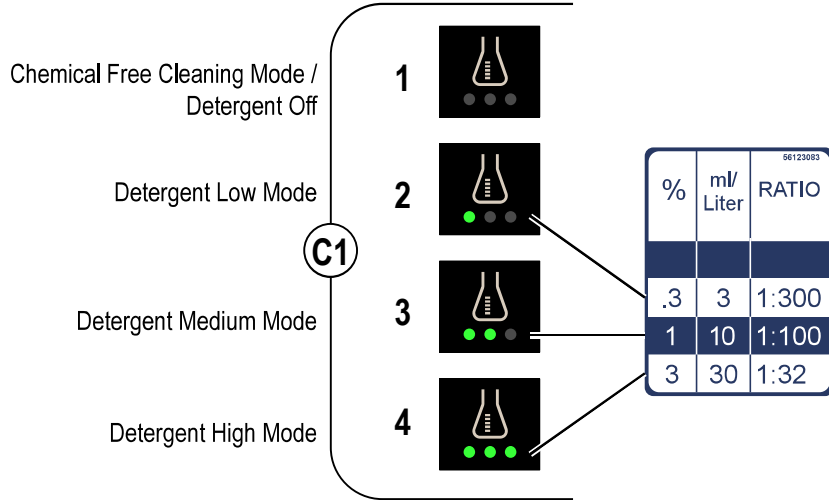

OPERATING THE MACHINE

WARNING!

Be sure you understand the operator controls and their functions.

While on ramps or inclines, avoid sudden stops. Avoid abrupt sharp turns. Use low speed down ramps.

Operating Modes

The Nilfisk Liberty SC60 has three operating modes:

- **Manual Operating Mode:** Provides normal functioning of the machine, without autonomy. In this mode the machine is driven and controlled by an operator, and operates in a conventional manner. The machine must be driven in the manual mode while creating routes the machine will follow during Autonomous Operation. This includes driving to and from the Home Markers. Full details of the Manual Operating Mode are contained in the *OPERATING THE MACHINE MANUAL MODE* section of this manual.
- **Autonomous Mode:** The Autonomous Operating Mode is used to perform scrubbing operations automatically, without active Operator involvement. This is done by teaching the machine a specific path to follow.
 - Routes may also include specific actions the machine will make while performing the scrubbing activity. Such actions might include knowing when to raise or lower the scrub deck, how much solution to dispense. When run, the route tells the machine exactly what to do; what path it should follow, and what scrubbing actions it should take along the way.
- **Teaching Mode:** Used to create routes the machine will follow when scrubbing autonomously. Before the machine can operate autonomously, the operator must teach a specific route to follow while scrubbing. During teaching, both the path to travel and scrub settings are recorded and saved.

STARTING THE MACHINE

- 1 Follow the instructions in "Preparing the Machine for Use" section of this manual and verify the following;
 - Home Marker is properly installed to a wall.
 - Home Marker Position is scanned (required for autonomous operation).
 - Vision and sensor lenses are clean, see *CLEAN SENSOR LENSES* section.
 - Batteries are fully charged.
 - Exterior of machine is free of damage. Report any damage to your supervisor.
 - Proper brush/pad is correctly installed.
 - Squeegee is installed.
 - Solution tank is full.
 - Recovery tank is empty.
 - Ensure that area to be scrubbed is clear of obstacles that are not fixed, such as hoses, buckets or pails, boxes, electrical cords, carts, pallets, etc.
 - Pre-sweep the area to be cleaned if debris is present.

WARNING!

Do not dispense flammable cleaning agents, operate the machine on or near these agents, or operate in areas where flammable liquids exist.

Do not operate machine in autonomous mode in the vicinity of elevated support platforms such as ladders, scaffolding, cherry pickers and similar items.

- 2 **See Figure 3-1.** Sit in the Operator's Seat (1), adjust the seat to a comfortable position using the Seat Adjustment Knob (17) under the seat panel.
- 3 Place the Key into the Key Switch (27) on the machine. Rotate the key clockwise to position (I) to turn ON the machine.

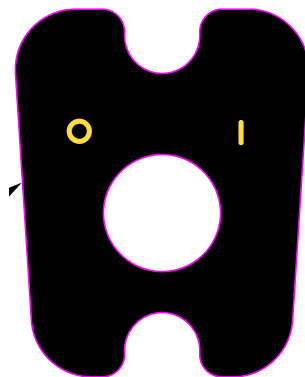

STARTING THE MACHINE - CONTINUED

- 4 At startup, the Autonomy Touchscreen Display (26) will briefly show the BrainOS logo and then show the PIN Entry Screen after about 1 minute..
- 5 Enter your 4-digit security PIN (1337) on the Autonomy Touchscreen.
NOTE: This security screen will also display after 3 minutes of the touchscreen not being touched. This is to ensure only authorized users can access the machine.
- 6 A Reminder screen will display regarding;
 - a. Cleaning the sensors
 - b. Check battery charge
 - c. Drain recovery tank
 - d. Fill solution tank
 Press OK
- 7 The Main Menu will then display.
 The time, battery level and ROC synchronization status are shown across the top of the screen.

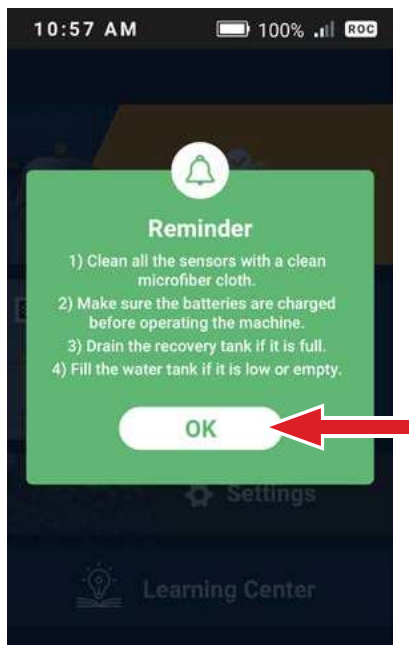

- 8 To transport the machine to the Home Marker, apply even pressure with your foot on the front of the Drive Pedal (3) to go forward or for reverse first press the Reverse Drive Switch (L) then press the front of the pedal. Reverse Drive Indicator (L1) will be lit in reverse mode and an audible alert will sound while moving in reverse. Vary the pressure on the foot pedal to obtain the desired speed.

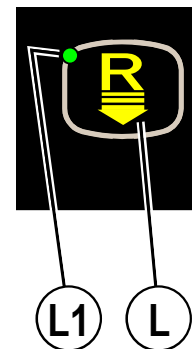

ROBOTIC OPERATIONS CENTER

BrainOS software provides access to the Brain Corporation Robotic Operations Center (ROC). The ROC is cloud-based and managed by Brain Corporation technicians. The ROC is connected by a built-in fourth generation (4G) Long-Term Evolution (LTE) modem and does not require user interaction to connect. New versions of the BrainOS software automatically download to the machine without disrupting service or requiring operator interaction.



The Figure above shows the ROC connection indicators seen at the top of the screen.

- When the machine is connected to the ROC, the screen displays the left icon.
- If the machine is not connected to the ROC, the screen displays the right icon. If the machine is not connected to the ROC, the ROC cannot be paired with a mobile device.

PAIR A MOBILE DEVICE TO ROC

Before running an autonomous route, it is recommended (but not required for operation) that the operator pair their mobile device with the ROC.

After pairing, the ROC sends messages to the mobile device if the machine requires assistance and a notification when the cleaning routes are complete.

To make sure that only the on-site operator receives alerts from the ROC, only one mobile device can be paired with the ROC at a time. A paired mobile device is automatically disconnected when the machine is turned off or when a new mobile device is paired.

To pair a mobile device to the ROC, follow these steps:

1. To turn on the machine, insert key and turn Key Switch **(27)** to the ON (I) position.
2. Wait for the screen to initialize.
3. Enter the 4-digit PIN 1337 on the Autonomous Touchscreen Display **(26)**. Upon successful PIN entry, the screen displays the Main Menu.
4. From the Main Menu, select Settings.
5. Select Notifications.
6. To pair the mobile device with the ROC, follow the instructions on the screen.

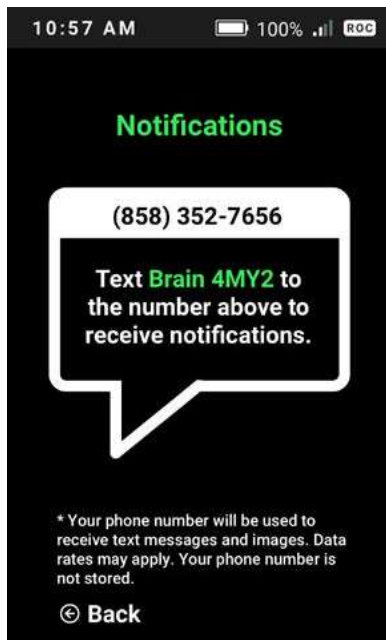

7. Use your mobile device to send the text message that appears on the autonomy touchscreen display to the number shown. The body of the message should include the text provided on the autonomy touchscreen display.
8. Pairing is successful when your mobile device receives a message that states "You've successfully been registered for alerts for this session".
NOTE: Sometimes SMS messaging can take several minutes due to standard wireless carrier transmission times.

ACCESS THE LEARNING CENTER

The Learning Center allows access to instructional video tutorials in multiple languages that describe how to perform common tasks, such as:

- **Home Marker placement**
- **Train a new route**
- **Run an existing route**

Access the videos by following these steps:

1. To turn on the machine, insert key and turn Key Switch **(27)** to the ON (I) position.
2. Wait for the screen to initialize.
3. Enter the 4-digit PIN 1337 on the Autonomous Touchscreen Display **(26)**. Upon successful PIN entry, the screen displays the Main Menu.
4. From the Main Menu, select Learn.

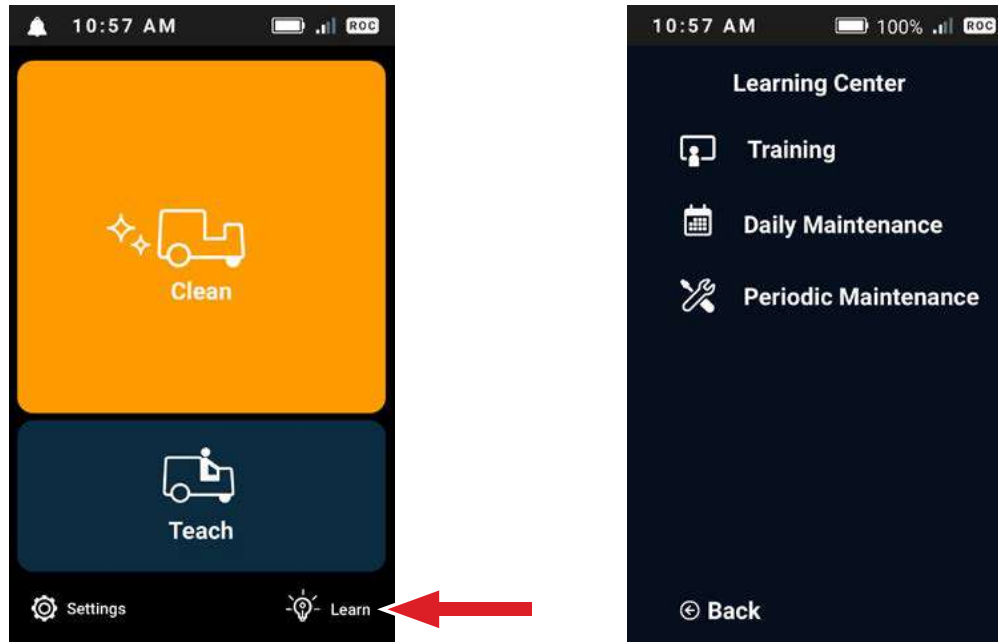

5. Select the applicable video.
 - a. To pause the video, touch the screen.
 - b. To resume the video, touch the screen again.

STOPPING THE MACHINE

- 1 Stop the machine by releasing the Drive Pedal (3) in manual mode.
- 2 In Autonomous Mode the machine can be stopped by pressing the Start/Pause Button (33) on the rear of the machine.
- 3 **ONLY IN THE EVENT OF AN EMERGENCY!**
To stop all machine functions immediately, press one of the two Emergency Stop (7, E).
 - The display will state "Emergency Stop Button Pressed".
 - Follow the directions on the screen.
 - To reset the machine functions, rotate the emergency stop clockwise.
 - Press "Confirm" to resume the previous action.
 - Emergency Stop can be activated in either Autonomous or Manual Modes but should only be used in the case of an emergency.

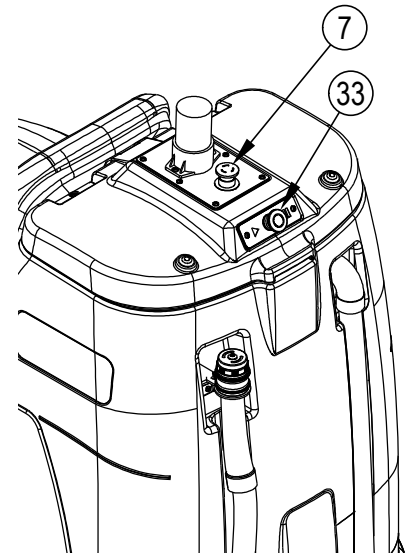
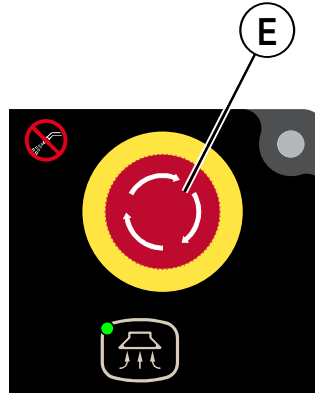

**Emergency Stop
Button Pressed**



1. Inspect the environment and the machine.
2. Clean any water left behind.
3. Release the emergency stop button by rotating it clockwise.

**Emergency Stop
Button Released**



Please confirm that the issue causing the emergency stop has been resolved.

By doing so the machine will resume the previous action.

Confirm

TEACH ROUTE FOR AUTONOMOUS MODE

The machine needs to be taught the exact route to be traveled while cleaning in autonomous mode before the route can be run. This route is saved along with scrub settings to use while cleaning.

- 1 Follow the instructions in ["Starting the Machine"](#) section. Once the main screen appears press "Teach".

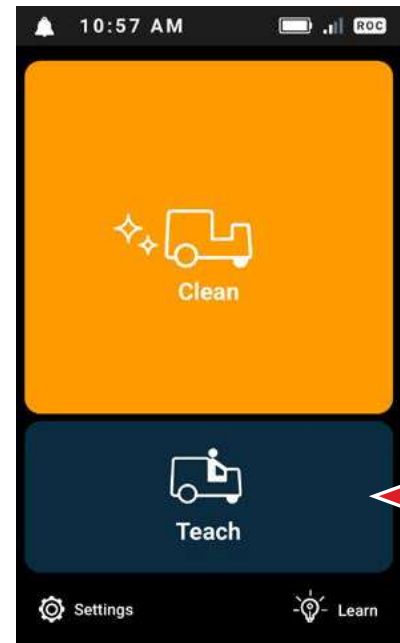

- 2 The touchscreen display will show the view of the right side camera. Manually drive the machine to the Home Marker until it is at a distance of 2 feet (0.6 m) and visible within the display. The Home Marker will be scanned automatically. A confirmation message will display after the Home Marker is successfully scanned.
NOTE: If the machine can not scan the Home Marker the display will show an error message with steps to correct the issue (i.e. Home Marker may be rotated).

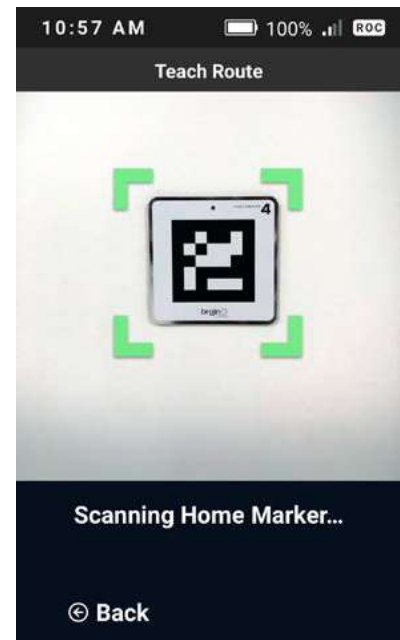

TEACH ROUTE FOR AUTONOMOUS MODE - CONTINUED

- 3 The screen will display a list of the six possible Routes A-F. Press the Route you want to teach.

NOTE: If all six routes are being used one of the existing routes will need to be deleted before a new one can be created. See "Delete a Route" on page 39.

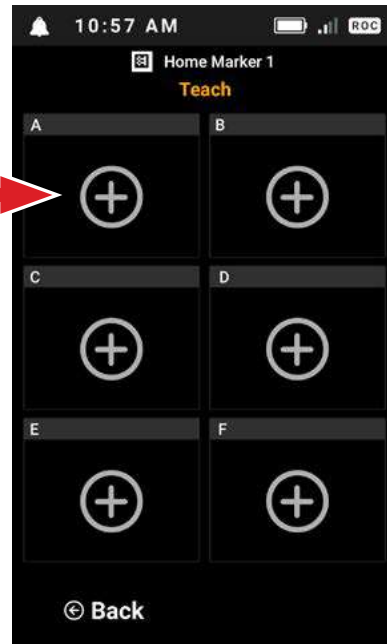

- 4 Machine display will indicate it is ready to learn the new route.
- 5 Decide where you want the route to start cleaning and manually drive the machine to the location. See "[Tips for Teaching a Route](#)" on page 32.

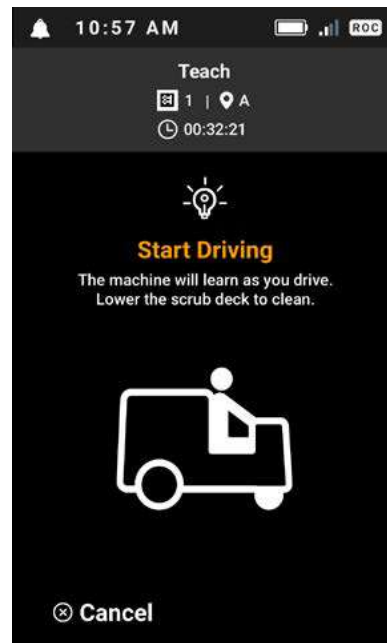

- 6 Press the One-Touch Scrub Switch (M) to lower scrub deck, squeegee and activate scrub and vacuum systems.
- e. Press One-Touch Scrub Switch (M) to turn scrubbing on/off where needed along the route. While teaching, the scrub settings are not recorded, only scrub on/off is recorded.

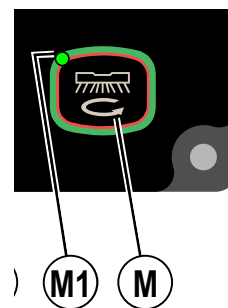

TEACH ROUTE FOR AUTONOMOUS MODE - CONTINUED

- 7 Begin to drive the machine along the route's path.
 - a. Touchscreen will display the machine is "Learning...".
- 8 Clean the area using the desired vacuum, solution, scrub and detergent settings.

- While teaching Route;

 - a. Operate all of the scrub functions. Clean the floor as if in manual mode. See section "OPERATING THE MACHINE MANUAL MODE" for more information on adjusting any of the scrub settings.
NOTE: Because scrubbing requirements can change from day to day the scrub settings are not recorded at the time of teaching and will be set at the time of running the route.
 - b. When scrub is turned ON or OFF will be recorded along with the route traveled.
 - c. If machine is driven without turning scrub ON while teaching, the route will be saved without scrubbing. Scrub ON/OFF can not be added later to the route. Scrub settings (scrub pressure, solution flow etc.) can be set after training the route.
 - d. The machine speed (including stops) and operator's use of the horn is not recorded while teaching, just the route.
 - e. The reverse switch is not selectable while teaching so plan route in advance to avoid backing up.
- 9 Stopping the machine while teaching brings up a "Learning Paused" screen. The operator has three options;
 - a. Drive to continue teaching route.
 - b. Press "Cancel" to delete the route without saving. Display allows to confirm Cancel or Resume (exit cancel).
 - c. Press "Save" to save the new route.

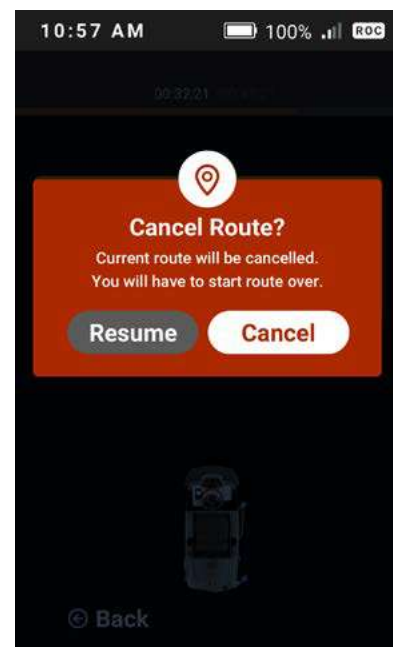
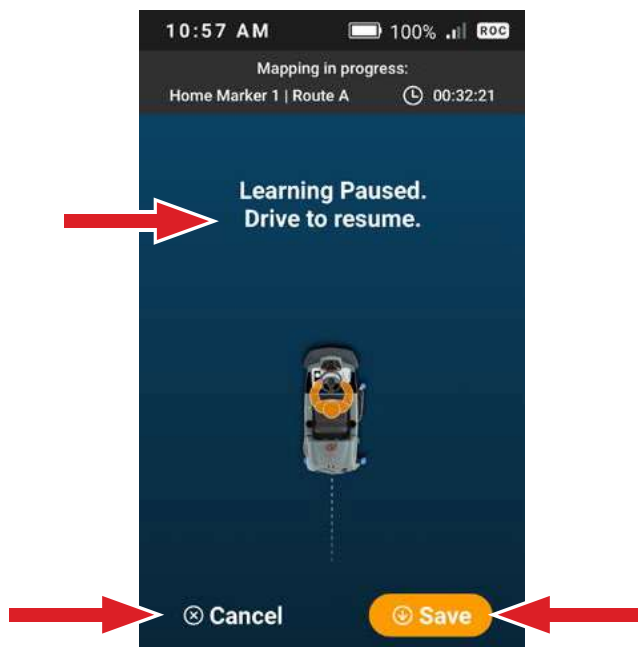
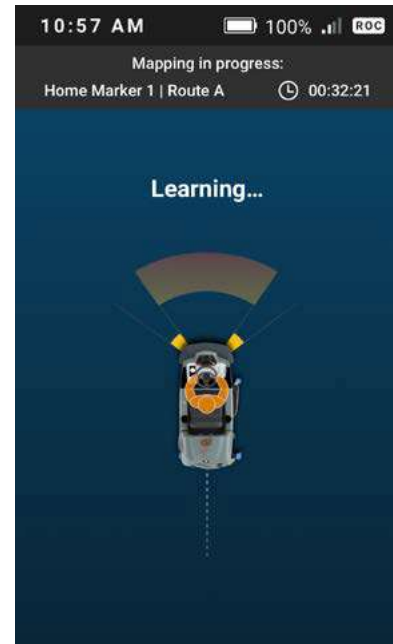

TEACH ROUTE FOR AUTONOMOUS MODE - CONTINUED

- 10 When the route is complete drive the machine back to the same Home Marker that was scanned at the beginning of the route.
- 11 Machine will automatically scan the Home Marker. **NOTE:** A new route can not be saved until the machine successfully scans the same Home Marker at the same physical location.
- 12 Once the Home Marker is scanned the machine will save the route and touchscreen display shows "Saving route...".
- 13 Press "Choose Label" to label your new route.

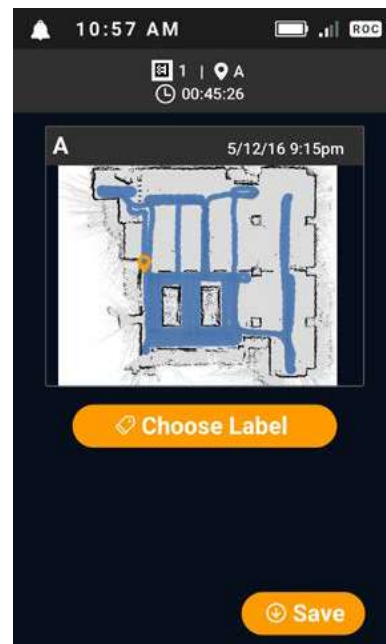
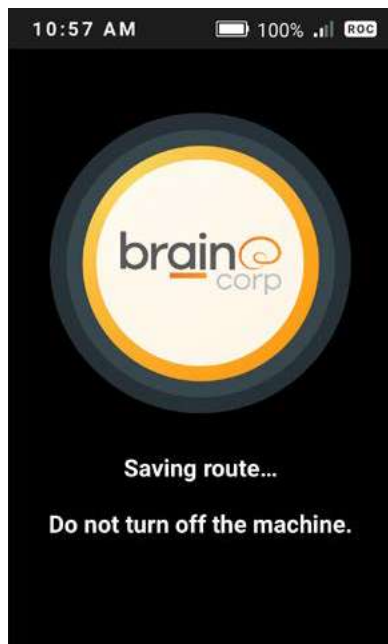
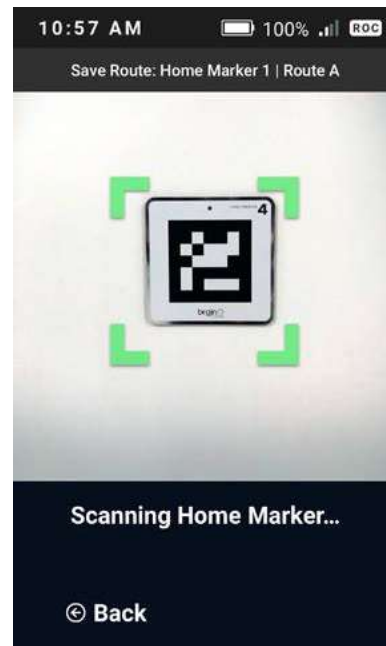

TEACH ROUTE FOR AUTONOMOUS MODE - CONTINUED

- 14 Select the desired label for this route, then press "Add Label".
- 15 The touchscreen displays the route with the label. The operator has three options;
 - a. Press "Edit Label" to change the label.
 - b. Press "Remove Label" to delete the label from the route.
 - c. Press "Save" to save the route with the new label.
- 16 The display will show "Route saved". If no label is chosen the route saved message will state "Route saved without label". A label can be added later if desired.
- 17 Once the route is saved it should be tested to see if it can be run successfully in autonomous mode. See "Run Autonomous Route" on page 35.

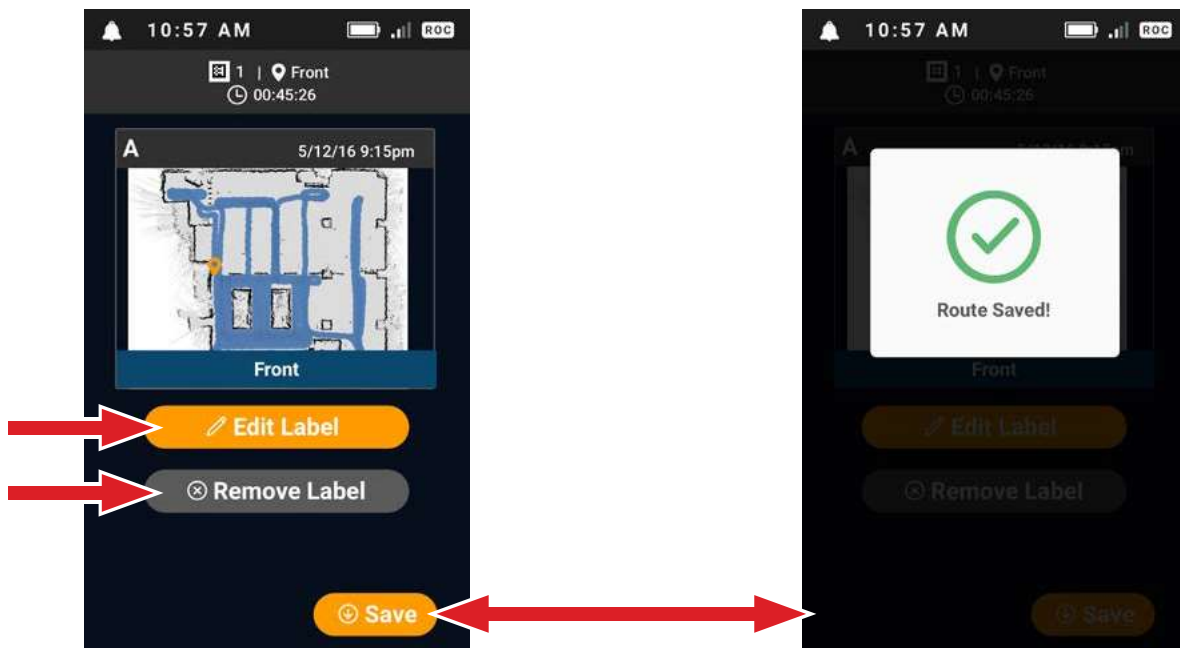
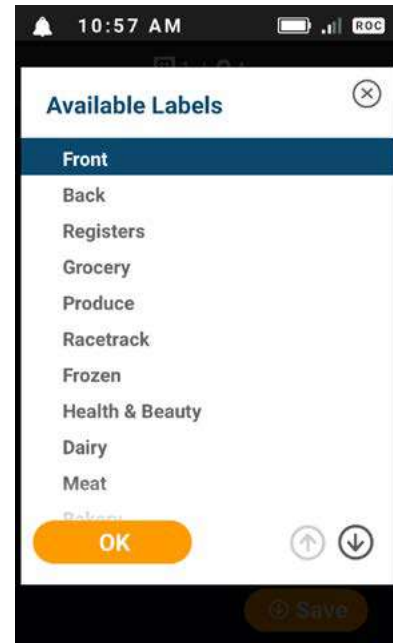

TEACH ROUTE FOR AUTONOMOUS MODE - CONTINUED

TIPS FOR TEACHING A ROUTE

- Do not teach new routes during busy hours. For best results teach the route at a time when there aren't people walking around in the area.
- Avoid sharp turns; keep them as smooth as possible to allow the squeegee to recover as much of the solution as possible.
- Drive in a straight line as much as possible.
- Teach routes only on a level floor without inclines or declines.
- Routes should not exceed 45 minutes of teaching; shorter routes reduce the possibility of low solution or full recovery tank alerts.
- Do not teach a route that would go into an elevator or through automatic doors.
- Because U-turns slow down the machine, it's better to circle around or alternate aisles wherever possible.
- Maintain a safe distance of approximately 1.5 ft (0.5 m) from the edge of ramps, platforms, drop-offs and glass. This includes escalators, elevators, and loading docks. Place a barrier or series of cones to prevent the machine from getting too close to these areas. The barrier or cones must measure at least 8 inches (20 cm) in height.
- Plan the area to be cleaned and divide the space into contiguous routes for maximum efficiency and yield.
- Optimize routes to account for other activities, such as restocking shelves.
- If a route is taught to go around obstructions that are later removed, the machine does not clean any areas previously occupied by those obstructions.
- Reteach a route whenever the dimensions of the space change significantly or whenever new features have been introduced or removed—such as merchandise displays—or if there are performance issues with an existing route.
- Machine will record the exact route the operator drives so great care should be taken to fully clean all the intended floor surface or any missed spots on the floor will be missed each time the route is played back.

INFORMATION INCLUDED IN A ROUTE

- Saved route guides machine movements during autonomous operation.
- Machine will follow exact route taught.
- Machine will record where it was trained to scrub (scrub ON) and not scrub (scrub OFF).
- Machine will drive around new obstacles detected but not part of route.
- Machine will not record the speed or stops and starts the operator performs while teaching. The machine will determine the speed it uses to run the route, ignoring anytime the operator stopped the machine while teaching. Speed will be reduced when cleaning along a wall or around an obstacle.

RUN ROUTE, AUTONOMOUS MODE

Once the operator has taught a route in an area the route can be run.

- 1 Follow the steps under ["Starting the Machine"](#). When the main menu screen appears press "Clean".
- 2 Drive the machine to the Home Marker that corresponds to the desired route. Machine will automatically scan the Home Marker and indicate successful scan.

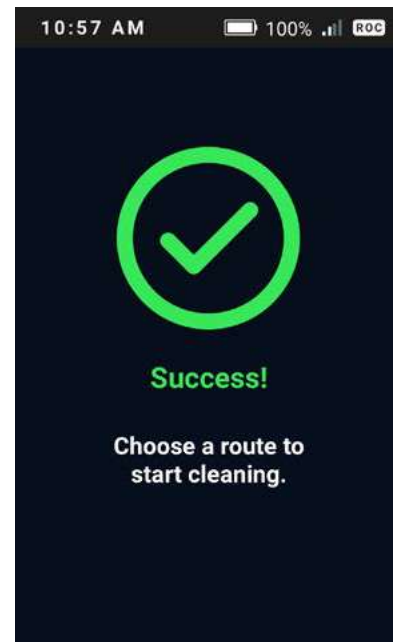

RUN ROUTE, AUTONOMOUS MODE - CONTINUED

- 3 The display will show the available routes associated with this Home Marker.
- 4 Press the route to run. Multiple routes can be run consecutively. Press each route to run in the order they should run. The order in which they will run is displayed in the upper right corner of each route. In the example shown Grocery route is #1 then "Paper / Pets" route is #2.
NOTE: Press any route a second time to remove it from the list and it will not run.
- 5 After the route(s) are selected, press Run.

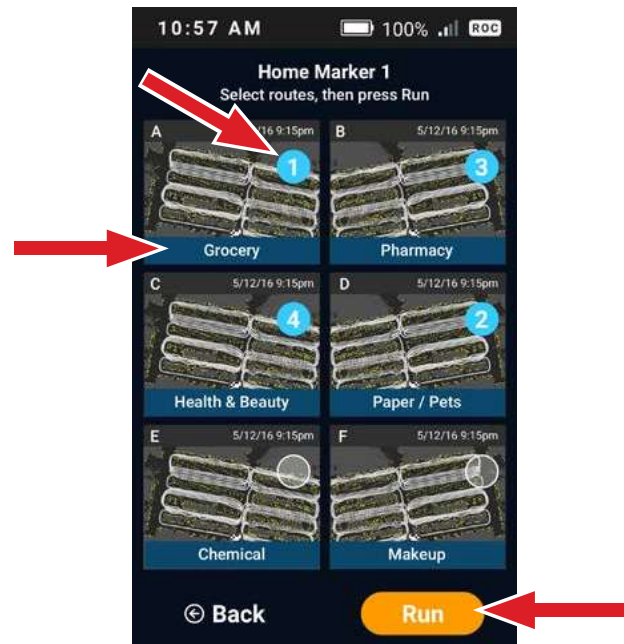

RUN ROUTE, AUTONOMOUS MODE - CONTINUED

- 6 Adjust solution flow and brush pressure (see Manual operation for details).
The route will run with a single set of scrub parameters throughout the entire route.
- 7 Without turning the key remove it from the key switch.
- 8 Step off the machine.
- 9 Secure the yellow safety straps to deter someone from sitting on the seat.



- 10 Press the Start/Pause Button (33).
 - a. The horn sounds as a warning to those in the area that machine will begin moving, autonomous mode is beginning.

CAUTION!

Do not place hands or feet below the scrub deck. Once the route begins to run the deck will lower without warning. There is a danger of being crushed.

WARNING!

Do not attempt to ride on the machine, use the steering wheel, or put hands or arms through the steering wheel when the machine is running a route in autonomous mode. The steering wheel can move rapidly and unexpectedly, which could cause physical injuries and disrupt machine operations.

- b. The display will show "Cleaning in progress" along with a progress bar and time spent on the route alongside an estimate of the total run time.
- c. The touchscreen is disabled while the machine is in autonomous mode. Touching the screen will display a "Screen Disabled" message, but does not stop the machine.

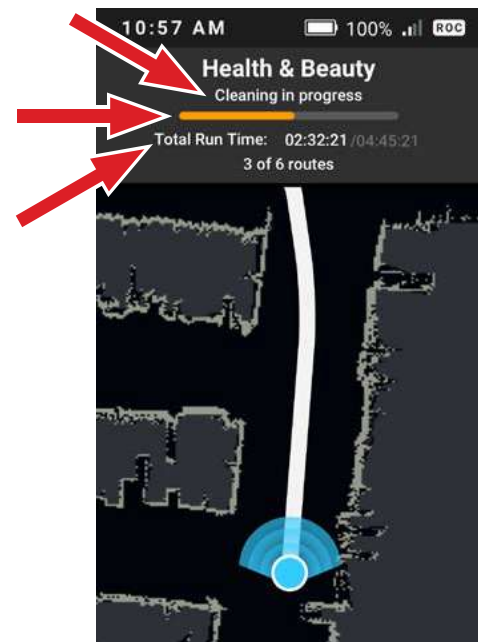
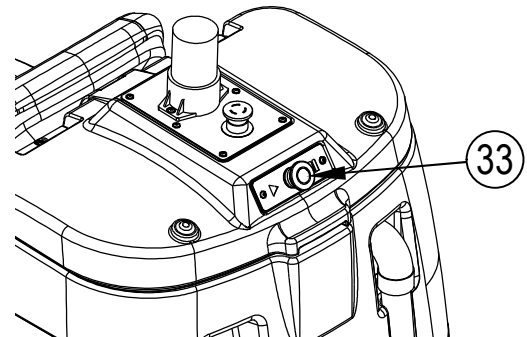

RUN ROUTE, AUTONOMOUS MODE - CONTINUED

- 11 Verify the machine is cleaning correctly. Press Start/Pause Button **(33)** to pause the route and adjust solution or scrub settings. To continue the route press Start/Pause Button **(33)** again. Monitor the side blades and rear squeegee during the first few minutes of running the route to ensure they are properly adjusted and not trailing water.

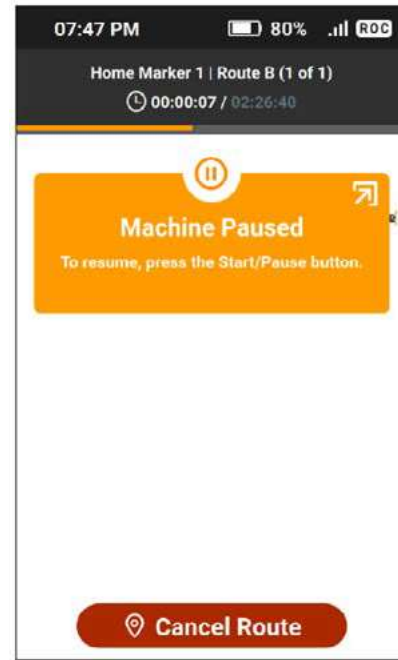

- 12 If the machine is paired with a mobile device it will receive an update when a route is complete.
 13 If the machine encounters an issue it will send a message to the mobile device "Robot Requires Assistance" along with an image from the front camera to aid in locating the machine.



- 14 After the route has completed go back to the machine and enter your 4-digit PIN 1337 to access the machine.
 15 The display will show the route and what areas were "Cleaned" and "Not Cleaned".
 a. The machine may have had to navigate around people or new obstacles so the area cleaned may not match up perfectly with the trained route.
 b. If consecutive routes were run then pressing the left or right arrows allows for review of those routes.
 16 Press "Done" to exit.

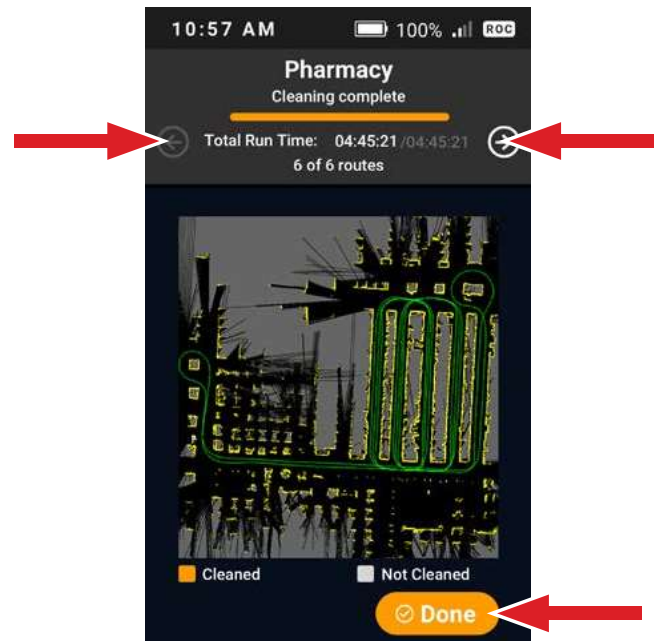

CANCEL ROUTE

While Cleaning in Autonomous Mode

- 1 Press Start/Pause Button (33).
 - a. To resume, press the Start/Pause button
 - b. To cancel the route, press "Cancel Route" on the touchscreen

When the route is canceled it is not deleted from the list of routes, it simply stops the running of the route at this time.

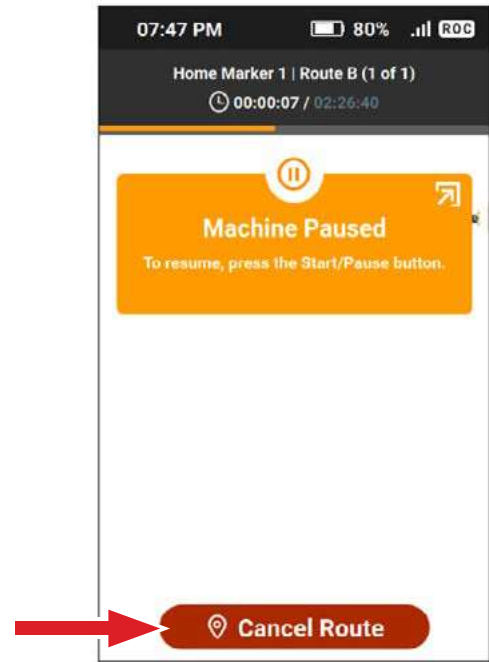

DELETE ROUTE

Each Home Marker supports a maximum of six routes. If all six spaces displayed on the screen are already filled with routes, the operator can only teach more routes by deleting one or more of the existing routes associated with that Home Marker.

To delete a route, start by following these steps;

- 1 To turn on the machine, insert key and turn Key Switch (27) to the ON (I) position.
- 2 Wait for the screen to initialize.
- 3 Enter the 4-digit PIN 1337 on the Autonomous Touchscreen Display (26). Upon successful PIN entry, the screen displays the Main Menu.
- 4 From the Main Menu, select Settings.



DELETE ROUTE - CONTINUED

5 Press "Routes".

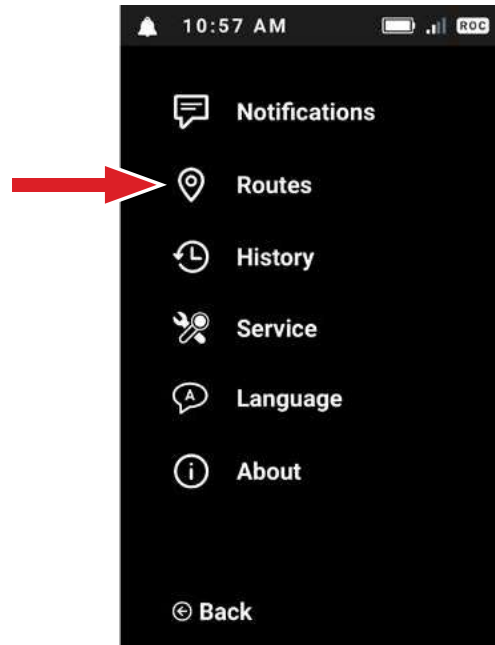

6 Press the Home Marker associated to the route that needs to be deleted.



DELETE ROUTE - CONTINUED

7 Press the route to be deleted.

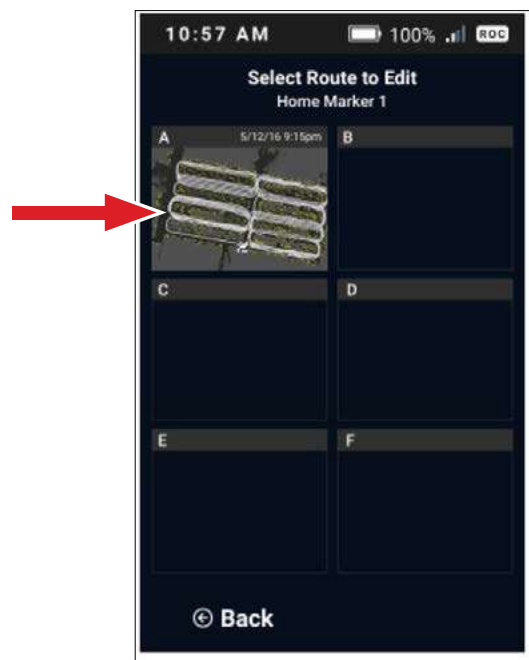

8 Press "Delete Route"

NOTE: From this screen there are also the options to "Edit Label" or "Remove Label".

9 Press "Delete" to permanently delete the route.

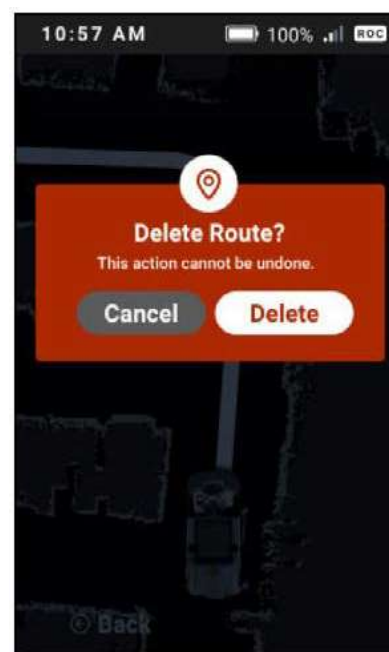

OPERATING THE MACHINE MANUAL MODE

WARNING!

Be sure you understand the operator controls and their functions.

While on ramps or inclines, avoid sudden stops. Avoid abrupt sharp turns. Use low speed down ramps.

1 Follow the instructions in "Starting the Machine" section and drive the machine to the work area to begin cleaning.

2 Press the One-Touch Scrub ON Switch (**M**) once for Regular Scrub. The brushes and squeegee are automatically lowered to the floor. The scrub, solution, vacuum and detergent systems are all automatically enabled and will start when the Drive Pedal (**3**) is pressed. Any individual system can be adjusted or turned OFF or ON by pressing its increase/decrease switches at any time during scrubbing.

Scrub Pressure: Scrub pressure can be adjusted by pressing the Scrub Pressure Increase Switch (**A+**) and Scrub Pressure Decrease Switch (**A**) to change between (Regular, Heavy, Extreme). Observe the Scrub Pressure Indicators (**A1**). The scrub system can only be turned OFF by pressing the One-Touch Scrub Switch (**M**).

Solution: The solution flow rate is increased or decreased independently of the scrub pressure by pressing the Solution Flow Increase Switch (**B+**), and Solution Flow Decrease Switch (**B**) to change between (Low, Medium, High and Off). Observe the Solution Flow Indicators (**B1**).

Vacuum: The vacuum is either ON (default) or OFF. Pressing the Vacuum Switch (**F**) will cycle between ON and OFF. While ON Vacuum On Indicator (F1) will be lit.

NOTE: To pick up solution without scrubbing, press the Vacuum Switch (**F**) while in transport mode. This will cause the squeegee to lower and the vac motor to turn ON.

Detergent: See "Detergent System Preparation and Use (EcoFlex)" for more detailed information regarding the adjustment and use of the detergent system.

3 Begin scrubbing by driving the machine forward in a straight line at a normal walking speed and overlap each path by 2-3 inches (5 - 7.6 cm). Adjust the machine speed and scrub parameters when necessary according to the condition of the floor.

4 Press the Burst of Power Switch (**D**) to temporarily (1 minute) increase detergent strength, scrub pressure and increase the solution flow rate to the next available level. The Burst of Power Indicator (**D1**) will flash, after which all scrub parameters will return to their previous state.

5 When scrubbing, check behind the machine occasionally to see that all of the used solution is being picked up. If there is water trailing the machine; you may be dispensing too much solution, the recovery tank may be full, there may be debris in the squeegee tool, squeegee blades may be worn or the squeegee tool may require adjustment.

6 The recovery tank has a Tank Full Switch that causes ALL systems to turn OFF except the drive system when the recovery tank is full. When this switch is activated, the recovery tank must be emptied. The machine will not pick up water or scrub with the switch activated.

NOTE: The Recovery Tank Full alert appears on the touchscreen when the switch is activated.

7 When the operator wants to stop scrubbing:

Press the One-Touch Scrub Switch (**M**) once. The scrub brushes and solution flow will stop and the scrub deck will raise. The squeegee will raise up after a brief delay and the vacuum will stop after an additional delay (this is to allow any remaining water to be picked up without turning the vacuum back on) if the vacuum switch is pressed during this time delay the vacuum will turn off.

8 Drive the machine to a designated waste water "DISPOSAL SITE" and empty the recovery tank. To empty, pull the Recovery Tank Drain Hose (**36**) from its rear storage area, then unscrew the cap (hold the end of the hose above the water level in the tank to avoid sudden, uncontrolled flow of waste water). The drain hose can be squeezed to regulate the flow. Lift open the Recovery Tank Cover (**29**) to inspect and empty the Debris Catch Tray (**32**) inside the recovery tank. Refill the solution tank and continue scrubbing.

NOTE: Make sure the Recovery Tank Cover (**29**) and the Recovery Tank Drain Hose (**36**) cap are properly seated or the machine will not pick-up water correctly.

When the batteries require recharging the touchscreen will display a message stating low battery, the scrub brushes and solution flow will stop and the scrub deck will raise up. The squeegee will raise up after a brief delay and the vacuum will stop after an additional delay. Transport the machine to a service area and recharge the batteries according to the instructions in the Charging Gel/AGM (VRLA) Batteries section of this manual.

FIGURE 3-11

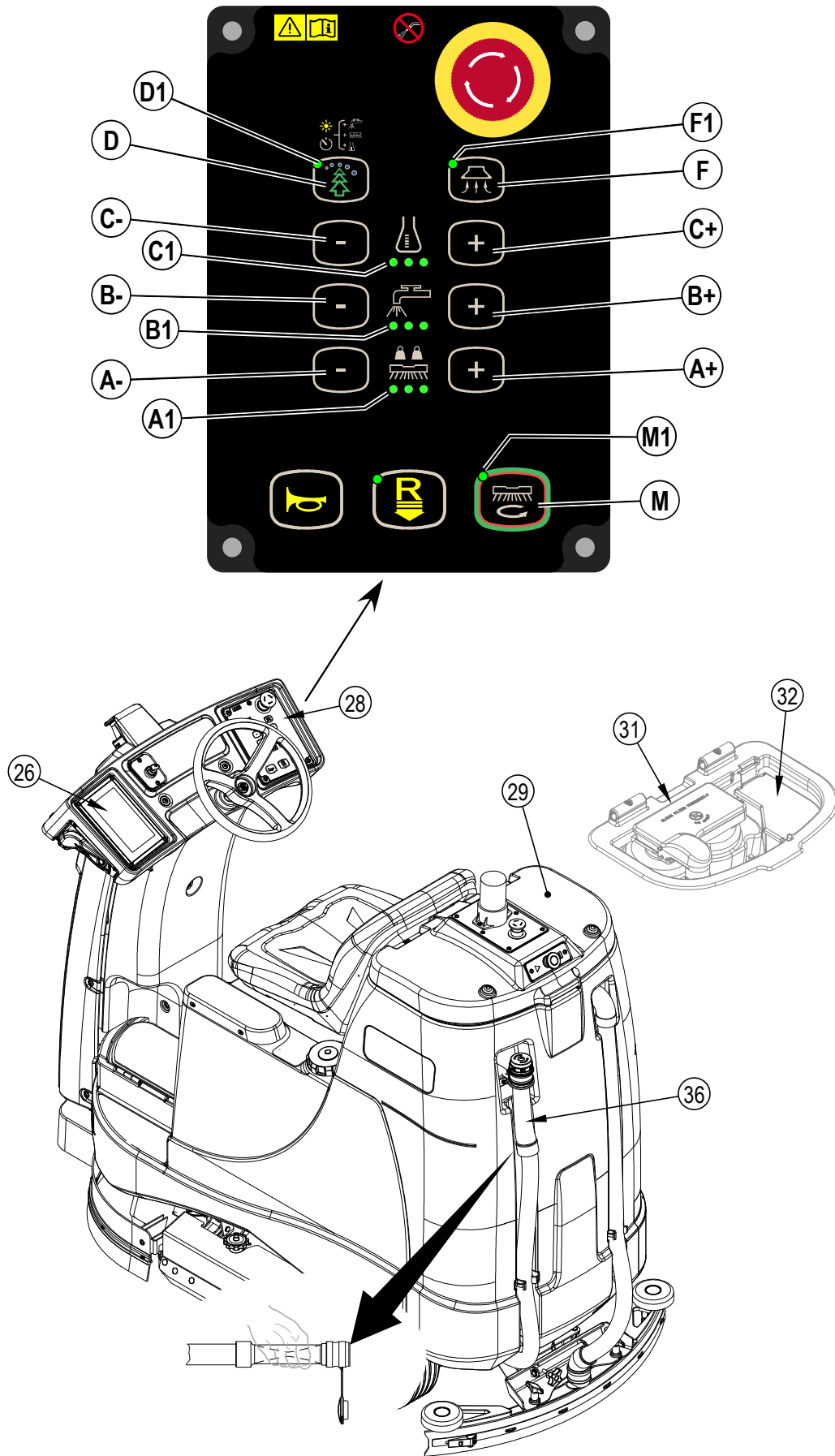

AFTER USE

- 1 When finished scrubbing, drive the machine to a service area for daily maintenance and review of other needed service upkeep.
- 2 To empty the recovery tank;
 - Pull the Recovery Tank Drain Hose **(36)** from its storage area.
 - Direct the hose to a designated "DISPOSAL SITE" and unscrew the cap (hold the end of the hose above the water level in the tank to avoid sudden, uncontrolled flow of waste water). The Recovery Tank Drain Hose can be squeezed to regulate the flow. Lower and release the hose to drain the tank.
 - Open the Recovery Tank Cover **(20)**.
 - Empty and rinse the Debris Catch Tray **(32)** in the recovery tank.
 - Thoroughly rinse the recovery tank with clean water, see "Cleaning Recovery Tank" section.
- 3 To empty the solution tank;
 - Solution tank needs to be emptied daily if detergent was mixed in the tank. Solution tank should also be emptied if machine is to be transported or stored for more than a few days.
 - Remove the Solution Tank Drain Hose **(2)** from its storage clamps.
 - Direct the hose to a designated "DISPOSAL SITE" and remove the drain hose cap.
 - Rinse the tank with clean water if detergent was used in the tank.
- 4 Inspect the squeegee and drain hoses; replace if kinked or damaged.
- 5 Remove the brush or pad holder see "Remove the Brush" section. Rinse it in warm water and hang up to dry or install back on machine.
- 6 Remove the squeegee, rinse it with warm water and hang it up to dry. Inspect the squeegee blades for wear or tears.
- 7 Remove the hopper on cylindrical systems and clean thoroughly. Remove from either side of the machine by tilting the hopper up and away from housing, then pull out.
- 8 Clean the machine using a damp cloth and where needed use a mild detergent. Do not use a spray hose to clean the exterior of the machine to prevent water ingress into sensitive electronics. Sensor lenses have specific cleaning instructions see "Clean Sensor Lenses".
- 9 Check the maintenance schedule below and perform any required maintenance before storage.
- 10 Store the machine indoors in a clean dry place. Keep from freezing. Leave the tanks open to help prevent odors.
- 11 Turn the Key Switch **(27)** OFF (O) and remove the key.
- 12 Batteries are one of the most expensive replacement items on this machine. To protect your investment and to get as many cycles from the batteries as possible, remember the following:
 - When installing batteries make certain the machine and charger are programmed for the correct battery type.
 - Batteries will last longer if they are kept fully charged.
 - Batteries will prematurely fail if stored in a discharged state.
 - Battery chargers will not over or undercharge the batteries.
 - Every day after use, the battery charger must be plugged in (even if the batteries are not fully depleted) and the charger must be allowed to run through a full charging sequence to fully charge the batteries. This may take 8-12 hours depending on the battery status.
 - Always have the charger plugged into an AC outlet if the machine will not be used for a longer period of time to keep the battery(s) charged.

MAINTENANCE**MAINTENANCE SCHEDULE**

MAINTENANCE ITEM	Daily	Weekly	Monthly	Yearly
Charge Batteries	X			
Check/Clean Tanks & Hoses	X			
Check/Clean the Brushes/Pads	X			
Check/Clean the Squeegee	X			
Check/Clean Vacuum Motor Fan Inlet Screen (31)	X			
Empty/Clean Debris Catch Tray (32) in Recovery Tank	X			
Clean 2D Drop-Off and 2D Mapping LIDAR (14 & 22) lenses see "CLEAN SENSOR LENSES"	X			
Front 2D and 3D camera (50 & 51) lenses see "CLEAN SENSOR LENSES"	X			
Left and Right 2D and 3D camera (52 & 53) lenses see "CLEAN SENSOR LENSES"	X			
Clean Hopper on Cylindrical System	X			
Inspect Blades in Side Blade Assemblies		X		
Inspect and clean Solution Filter (42)		X		
Purge Detergent System		X		
Clean Solution Trough and Drip Tubes on Cylindrical System		X		
Lubrication of Machine			X	
* Check Carbon Brushes				X

* Have an Authorized Nilfisk Service Center check the vacuum motor carbon motor brushes after 1200 operating hours (replace motor after 2000 recovery hours).

NOTE: Refer to the Service Manual for more detail on maintenance and service repairs.

CLEANING RECOVERY TANK

- 1 Drive the machine to the appointed disposal area.
- 2 Ensure that the machine is off and the key is removed from the Key Switch **(27)**.
- 3 Pull the Recovery Tank Drain Hose **(36)** from its storage area.
- 4 Direct the hose to a designated "DISPOSAL SITE" and unscrew the cap (hold the end of the hose above the water level in the tank to avoid sudden, uncontrolled flow of waste water). The Recovery Tank Drain Hose can be squeezed to regulate the flow. Lower and release the hose to drain the tank.
- 5 Lift open the Recovery Tank Cover **(29)**.
- 6 Rinse the recovery tank out thoroughly to remove any and all debris from the tank. To clean out the recovery tank leave the drain hose open to a floor drain and spray the inside of the tank clean with a hose. A hose with a spray attachment can be used to spray out the recovery tank but should not be directed to the vacuum motor inlet. Do not allow sprayed water to splash outside of tank or into the vacuum motor inlet.
NOTE: The spray hose should not be used to clean the exterior of the machine near the operator control panel and sensors to prevent water ingress into sensitive electronics.
- 7 Remove the Debris Catch Tray **(32)** from the recovery tank. Empty and rinse the debris catch tray then reinstall it.
- 8 Open the Vacuum Motor Filter Housing **(31)** and remove the filter. Remove any debris that has gathered inside the filter housing. Rinse the filter then reinstall.
- 9 Check the condition of the recovery tank cover gasket and the area it seats against. They should be clean to create a good seal.
NOTE: The gasket allows the creation of a vacuum in the tank, which is necessary to vacuum up the recovery water.
- 10 Close the recovery tank cover. If finished cleaning for the day the tank cover can be left open to air dry and avoid odors.

CLEANING SOLUTION FILTER

- 1 Drive the machine to the appointed disposal area.
- 2 Ensure that the machine is off and the key is removed from the Key Switch (27).
- 3 **See Figure 4-2.** Close the Solution Shutoff Valve (41).
- 4 Unscrew the solution Filter Cover (42). There will likely still be some solution in the line that will spill out.
- 5 Clean the filter cover and screen.
- 6 Reinstall the screen and cover, ensure the gasket is in place.
- 7 Open the Solution Shutoff Valve (41).

FIGURE 4-2

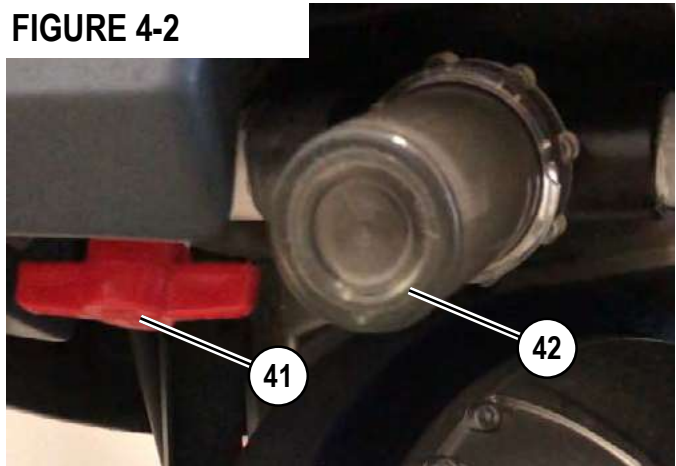

CLEAN SENSOR LENSES

⚠ CAUTION!

Do not use any harsh cleaning detergents or abrasive cleaning agents on the sensor lenses or damage may occur. Only clean the lenses as needed to reduce the chance of scratching them.

- 1 **See Figure 4-3.**
 - Clean 2D Drop-Off LIDAR lens (14) and 2D Mapping LIDAR lens (22) using an optical grade microfiber cloth dampened with lens cleaning solution.
 - Clean Front 2D Environment Camera lens (50) and 3D Obstacle Camera lens (51) using an optical grade microfiber cloth dampened with lens cleaning solution.
 - Clean Left and Right 2D Environment Camera lenses (52) using an optical grade microfiber cloth dampened with lens cleaning solution.
 - Clean Left and Right 3D Obstacle Camera lenses (53) using an optical grade microfiber cloth dampened with lens cleaning solution.

FIGURE 4-3



LUBRICATING THE MACHINE

Once a month apply grease to lubricate the following:

Use grease type Lubriplate® 730-2 or equivalent

- Steering Chain
- General Pivot Points for the Squeegee and Scrub Deck Linkage
- Side Blade Assembly Height Adjustment Knobs

CLEAN DRIP TUBES & SOLUTION TROUGH (CYLINDRICAL SYSTEM)

See Figure 4-4 . The cylindrical scrub deck has two Drip Tubes (BB) that attach to the solution hose tee and feed water to the scrub deck. The scrub deck has a trough with holes (BC) in it that allow solution to flow to the scrub brushes. Remove the drip tubes to clean the tubes and trough.

- 1 Use a short screwdriver to pry up on the cap end of Drip Tube (BB) to disconnect the end of the tube from the scrub deck.
- 2 Lift the end of the tube and remove the tube by twisting slightly and pulling the tube out to separate it from the solution hose tee.
- 3 Clean out trough holes and clean holes in the drip tube using a 16 gauge or smaller nail, toothpick or small brush. Use of a mild cleaning solution, such as vinegar, may help break down and wash away water scale.
- 4 Reinstall drip tube by pressing the end into the solution hose tee. Press the cap end down to clip onto the scrub deck. **NOTE:** Ensure holes in drip tube are aligned with holes in solution trough.

FIGURE 4-4

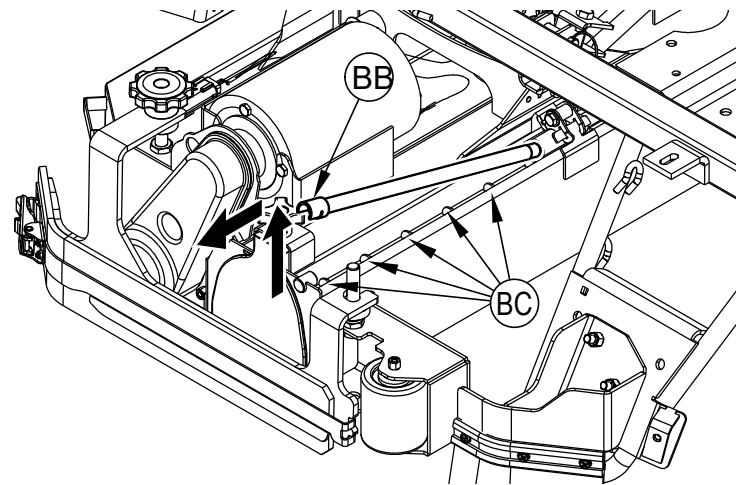

ELECTROMAGNETIC BRAKE

See Figure 4-5 . The Drive Wheel Assembly (4) has a built-in electromagnetic brake that is engaged whenever the Master Key Switch (A) is OFF or the FWD / REV Drive Pedal (3) is in the neutral position. This brake can be manually overridden if necessary by inserting a medium to large screwdriver behind the Yoke (AA) as shown. This should only be done in the event you need to push or pull the unit. Remember to remove the spacer (screwdriver) the brake arm after the machine is moved.

CAUTION!

Disconnect the batteries before reaching into this area. Severe injury could occur if steering components suddenly move.

FIGURE 4-5

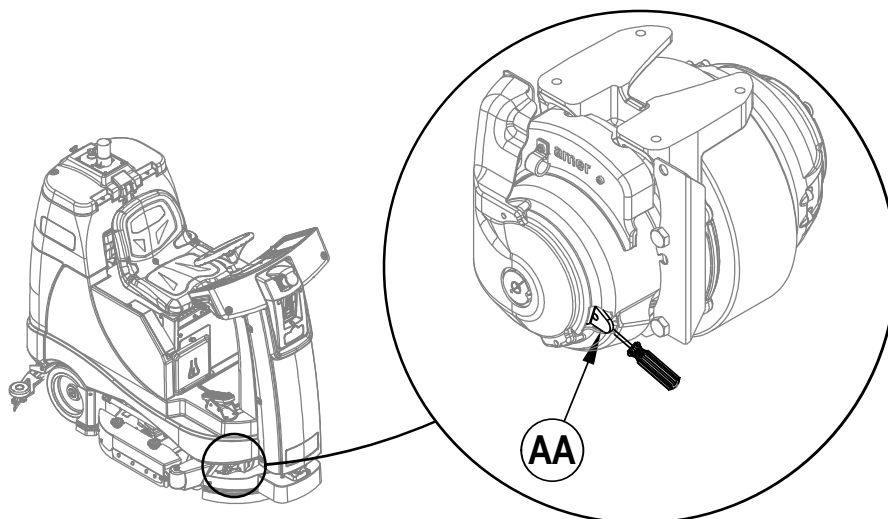

CHARGING GEL/AGM (VRLA) BATTERIES

Charge the batteries each time the machine is used or when the Battery Indicator (O) is reading less than fully charged.

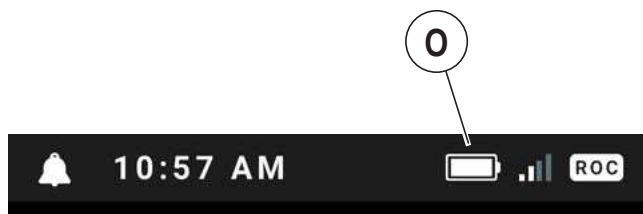

⚠ WARNING!

Charge batteries in a well-ventilated area. If battery acid makes contact with your skin, flush the affected area with water for 5 minutes and seek medical attention.

Do not smoke while servicing the batteries.

When Servicing Batteries...

- * Remove all jewelry
- * Do not smoke
- * Wear safety glasses, rubber gloves and a rubber apron
- * Work in a well-ventilated area
- * Do not allow tools to touch more than one battery terminal at a time
- * ALWAYS disconnect the negative (ground) cable first when replacing batteries to prevent sparks.
- * ALWAYS connect the negative cable last when installing batteries.

⚠ CAUTION!

Your valve regulated lead acid (VRLA) battery will deliver superior performance and life **ONLY IF IT IS RECHARGED PROPERLY!** Under or overcharging will shorten battery life and limit performance. Be sure to **FOLLOW PROPER CHARGING INSTRUCTIONS!** **DO NOT ATTEMPT TO OPEN THIS BATTERY!** If a VRLA battery is opened, it loses its pressure and the plates become oxygen contaminated. **THE WARRANTY WILL BE VOIDED IF THE BATTERY IS OPENED.**

The machine utilizes a shelf charger. To begin charging do the following:

- 1 Turn the machine off at the Key Switch (27).
- 2 Tip the seat forward to open the Battery Compartment (10) set the Prop Rod.
- 3 Disconnect the batteries from the machine and push the connector from the charger into the Battery Pack Connector (39).

SERVICE NOTE: Make sure you plug the battery charger into the connector that attaches to the batteries.

- 4 Refer to the charger's OEM product manual for more detailed operating instructions.

NOTE: Rely on the status lights on the charger (and its OEM manual) to verify when the batteries are completely charged. This may take several hours depending upon the condition of the batteries before charging.

IMPORTANT: Make sure you have an appropriate charger for use on Gel cell batteries. Use only "voltage-regulated" or "voltage-limited" chargers. Standard constant current or taper current chargers **MUST NOT** be used.

SQUEEGEE MAINTENANCE

If the squeegee leaves narrow streaks or water, the blades may be dirty or damaged. Remove the squeegee, rinse it under warm water and inspect the blades. Reverse/flip or replace the blades if they are cut, torn, wavy or worn.

To Reverse or Replace the Rear Squeegee Wiping Blade...

- 1 See Figure 4-7. Raise the squeegee tool off the floor, then unsnap the Rear Squeegee Blade Removal Latch (37) on the squeegee tool.
- 2 Remove the Tension Strap (AA).
- 3 Slip the rear blade off the alignment pins.
- 4 The squeegee blade has 4 working edges. Turn the blade so a clean, undamaged edge points toward the front of the machine. Replace the blade if all 4 edges are nicked, torn or worn to a large radius.
- 5 Install the blade, following the steps in reverse order and adjust the squeegee tilt.

To Reverse or Replace the Front Squeegee Blade...

- 1 Raise the squeegee tool off the floor, then loosen the (2) Thumb Nuts (AB) on top of the squeegee and remove the squeegee tool from the mount.
- 2 Loosen the Front Squeegee Blade Removal Thumb Nut (AE), then remove Tension Strap (AC) and blade.
- 3 The squeegee blade has 4 working edges. Turn the blade so a clean, undamaged edge points toward the front of the machine. Replace the blade if all 4 edges are nicked, torn or worn to a large radius.
- 4 Install the blade, following the steps in reverse order and adjust the squeegee tilt.

SQUEEGEE ADJUSTMENT

There are two squeegee tool adjustments possible, angle and height.

Adjust the squeegee angle whenever a blade is reversed or replaced, or if the squeegee is not wiping the floor dry.

- 1 Park the machine on a flat, even surface and lower the squeegee. Then drive the machine forward enough to have the squeegee blades fold over to the rear.
- 2 Adjust the squeegee tilt and height using the Squeegee Tilt Adjust Knob (35) and Squeegee Height Wheel (AD) so that the rear squeegee blade touches the floor evenly across its entire width and is bent over slightly as shown in the squeegee cross section.

FIGURE 4-7

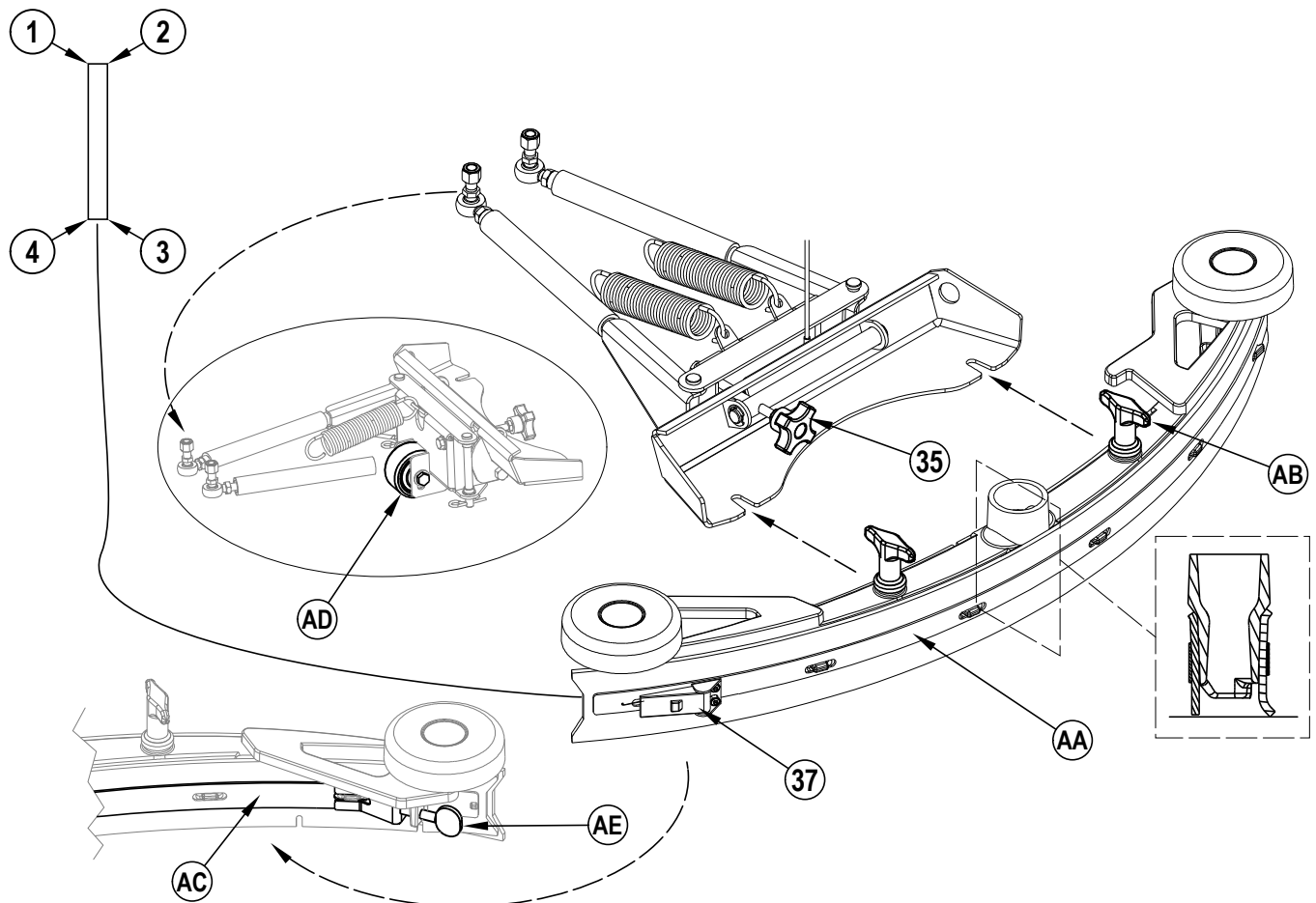

SIDE BLADE MAINTENANCE

The side blades' function is to channel the waste water to the squeegee, helping contain the water within the machine's cleaning path. During normal use the blades will wear in time. The operator will notice a small amount of water leaking out underneath the side blades. A height adjustment can easily be made to lower the blades so that all the water can be picked up by the squeegee.

To reverse or replace the scrub system side blades(s)...

- 1 See Figure 4-8. Loosen the (2) side blade Removal Knobs (15) (2 per side) and pull the Side Blade Assemblies (AA) slightly forward and then off from the scrub deck.
- 2 **DISC** - Remove all the hardware that holds the blades to the blade housing assembly.
CYLINDRICAL - Unlatch the retaining strap (AC) and remove the strap and blade.
- 3 Replace the blades as a set if they are nicked, torn or worn beyond their ability to be adjusted.
- 4 Reinstall the blade housing assemblies onto the machine and adjust the blade for proper contact to the floor when the brush deck is placed in the scrub position.

SIDE BLADE HEIGHT ADJUSTMENT

- 1 See Figure 4-8. The side blade assembly studs have leveling Adjuster Collars (19), that are to be raised or lowered to compensate for blade wear.
- 2 To adjust, remove the Blade Assemblies (AA) from the Scrub Deck (AB) to access the Adjuster Collars (19). Adjustment Tip: The blade's Removal Knobs (15) can be loosened with blades left on and the Adjuster Collars (19) rotated by reaching under the blade assembly housing.
- 3 Turn the Adjuster Collars (19) (Up or Down) to where the blades just fold over enough when scrubbing that all the waste water is contained inside the blades.

Note: Make small adjustments to obtain good blade wiping. Do not lower the blades too much to where they fold over excessively and cause unneeded blade wear. Make sure Blade Assembly (AA) is between Adjuster Collars (19) and Knobs (15).

FIGURE 4-8

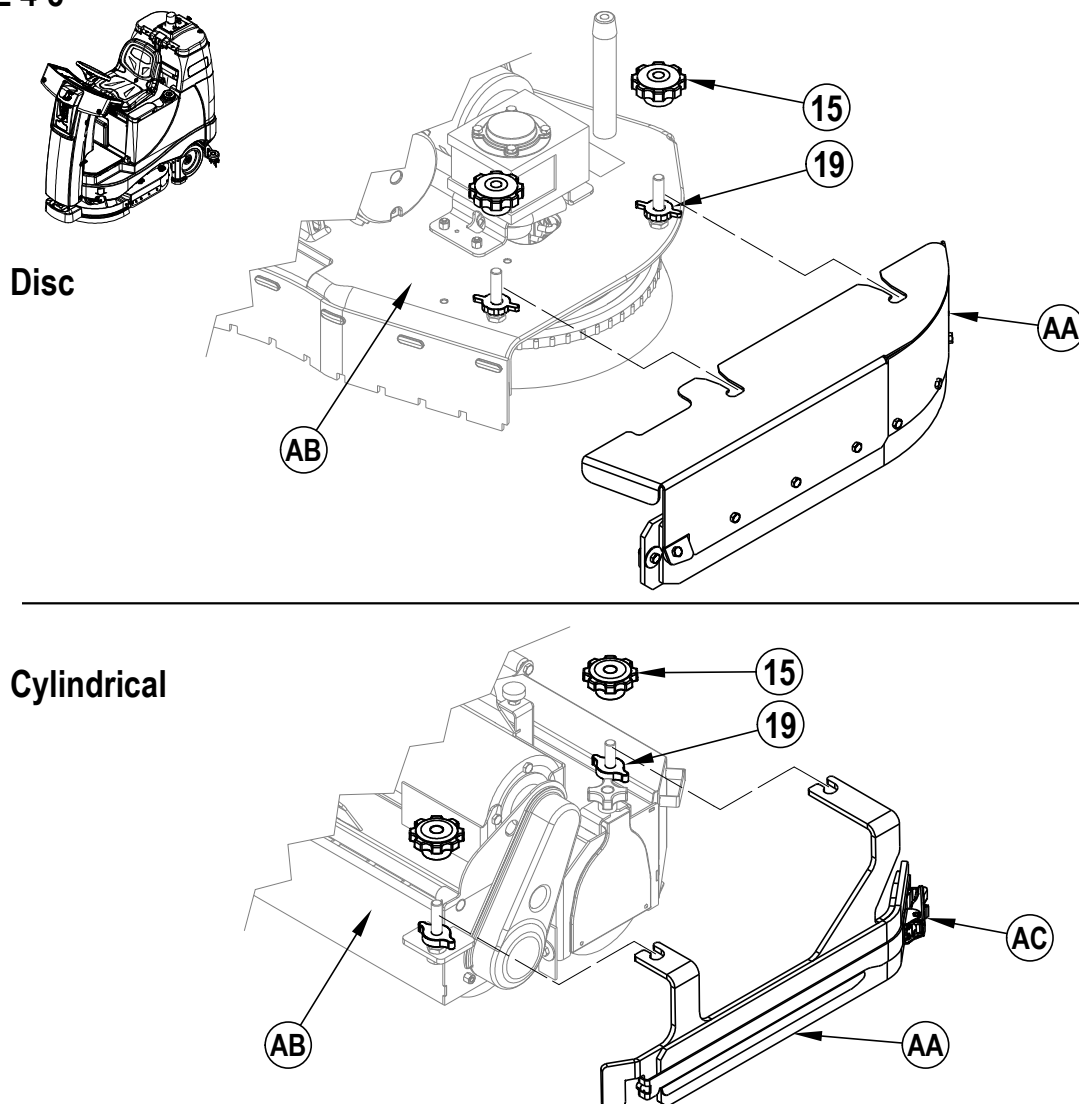

TROUBLESHOOTING

GENERAL MACHINE TROUBLESHOOTING

Problem	Possible Cause	Remedy
Poor water pick-up	Worn or torn squeegee blades	Reverse or replace
	Squeegee out of adjustment	Adjust so blades touch floor evenly across entire width
	Recovery tank full	Empty recovery tank
	Recovery Tank Drain Hose (36) leak	Secure drain hose cap or replace
	Recovery tank cover gasket leak	Seat gasket properly / Replace gasket
	Debris caught in Squeegee (11)	Clean squeegee assembly
	Recovery Hose (34) clogged or disconnected	Remove debris, connect hose to squeegee
	Using too much solution	Reduce flow via control panel solution switch
Poor scrubbing performance	Vacuum OFF	Turn vacuum ON
	Worn brush or pad	Replace brush or pad
	Wrong brush or pad type	Consult Nilfisk
	Wrong cleaning detergent	Consult Nilfisk
	Moving machine too fast	Slow down
	Not using enough scrub pressure	Increase scrub pressure
	Not using enough solution	Increase solution flow
Poor Sweeping Performance (Cylindrical System)	Solution is not flowing correctly	See "Inadequate or no solution flow" section in this table
	Hopper Full	Empty and clean hopper
	Brushes worn	Replace brushes
Inadequate or no solution flow	Bristles have taken a set	Rotate brushes
	Solution tank empty	Fill solution tank
	Solution filter (42), lines or valves clogged	Clean solution filter and flush lines
	Solution Shutoff Valve (41) closed	Open solution shutoff valve
	Solution Solenoid (43) plugged or defective	Clean or replace solenoid
	Solution pump (44) air locked	(contact Nilfisk Authorized Service Center)
Machine does not power ON	Solution drip tubes or trough plugged (cylindrical only)	Remove drip tubes clean holes in tubes and trough
	Machine Battery Connector (39) disconnected	Reconnect battery connectors
No FWD/REV wheel drive	Blown Main Fuse 150 Amp (F1)	Replace Main Fuse 100 Amp
	Emergency Stop (E or 7) activated, touchscreen display will indicate an alert "Emergency Stop Button Pressed."	Reset the Emergency Stop
No Detergent Flow	Drive system speed controller	Check error fault codes (contact Nilfisk Authorized Service Center)
	Empty Detergent Cartridge (13)	Fill detergent cartridge
	Plugged or kinked detergent flow line	Purge system, straighten lines to remove any kinks
	Detergent pump	Check pump, wiring and lines

TRIPPING THE CIRCUIT BREAKERS

The circuit breakers are located in the operator's compartment. To access the circuit breakers open the Electrical Compartment Access Door (16). Circuit breakers protect electrical circuits and motors from damage due to overload or short circuit conditions. If a circuit breaker trips check for anything that may be binding the affected motor. If source of the trouble is not apparent contact Nilfisk Service Center.

Circuit Breaker (CB)	Amp Rating	Motor
Traction CB24	70 Amp	Traction (Drive Wheel)
Scrub Brush CB5	30 Amp	Scrub Brush
Scrub Brush CB6	30 Amp	Scrub Brush
Vacuum CB7	20 Amp	Vacuum
Deck CB10	5 Amp	Scrub Deck Lift Actuator
Squeegee CB9	5 Amp	Squeegee Lift Actuator

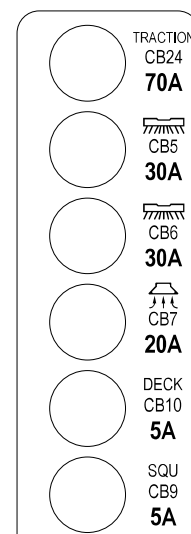

ALERT DISPLAY

Any Alerts detected by the machine will be displayed on the touchscreen as they occur. If more than one alert exists, the display will show them consecutively. Press the down and up arrows to scroll through the alerts. The number of alerts will display at the top of the screen.

Alerts are displayed as follows;

- Brief description of the alert will appear in the center of the screen
- The steps to resolve the alert are listed
- Press the "Back" arrow to exit the alerts screen

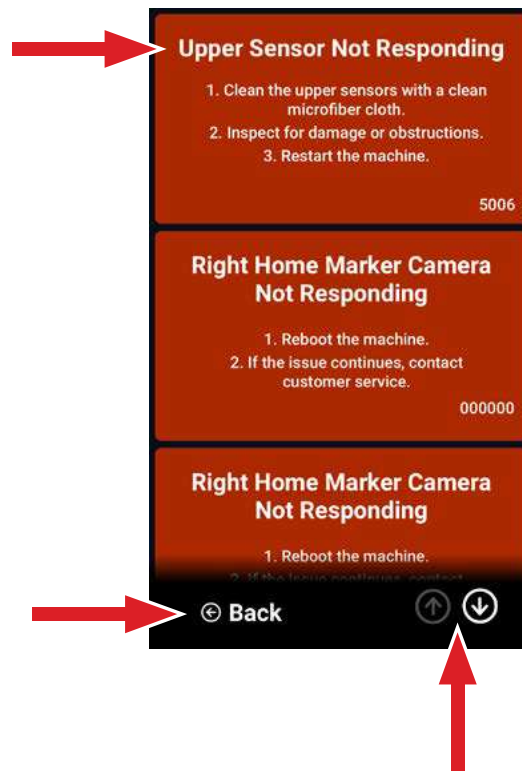

SPECIFICATIONS

ACCESSORIES / OPTIONS

In addition to the standard components, the machine can be equipped with the following accessories/options, according to the machine specific use:

Disc Machines

- Brushes with harder or softer bristles
- Pads with more or less abrasiveness

For further information about the above-mentioned accessories, contact an authorized Retailer.

MATERIAL COMPOSITION AND RECYCLABILITY

Material Composition and Recyclability		
Type	% of machine weight	% recyclable
Aluminum	3.5%	100%
Electrical / motors / engines - misc.	22%	40%
Ferrous metals	30%	100%
Harnesses / cables	9.25%	80%
Liquids	0%	0%
Plastic - non-recyclable	1.25%	0%
Plastic - recyclable	1.5%	100%
Polyethylene	27%	90%
Rubber	5.5%	30%

SOLUTION FLOW RATES

Manual Mode	Flow Rates At Full Manual Speed*		
	1 LED	2 LEDs	3 LEDs
	0.29 GPM / 1.11 liters/minute	0.63 GPM / 2.40 liters/minute	0.90 GPM / 3.44 liters/minute

* Flow rates are proportional to speed

TECHNICAL SPECIFICATIONS

(AS INSTALLED AND TESTED ON THE UNIT)

Model		Nilfisk Liberty SC60 X71D	Nilfisk Liberty SC60 X71C
Model No.		56123000	56123002
Voltage, Batteries	V	24V	24V
Battery Capacity (max)	Ah	390	390
Protection Grade		IPX3	IPX3
Sound Pressure Level IEC 60335-2-72: 2002 Amend. 1:2005, ISO 11203, ISO 3744	dB(A)/20µPa	57	65
Sound Pressure level - KpA (IEC 60335-2-72, ISO 11203) Uncertainty	dB(A)	3.0	3.0
Gross Vehicle Weight*	lbs / kg	1499 / 680	1517 / 688
Transportation Weight**	lbs / kg	1102 / 500	1135 / 515
Maximum Wheel Floor Loading – Manual (center front)	lbm/in ² / kg/cm ²	185.6 / 13.0	185.6 / 13.0
Maximum Wheel Floor Loading – Manual (right rear)	lbm/in ² / kg/cm ²	186.3 / 13.1	186.3 / 13.1
Maximum Wheel Floor Loading – Manual (left rear)	lbm/in ² / kg/cm ²	189.2 / 13.3	189.2 / 13.3
Maximum Wheel Floor Loading – Autonomous (center front)	lbm/in ² / kg/cm ²	157.5 / 11.1	157.5 / 11.1
Maximum Wheel Floor Loading – Autonomous (right rear)	lbm/in ² / kg/cm ²	161.1 / 11.3	161.1 / 11.3
Maximum Wheel Floor Loading – Autonomous (left rear)	lbm/in ² / kg/cm ²	172.1 / 12.1	172.1 / 12.1
Vibrations at the Hand Controls (ISO 5349-1)	m/s ²	0.93	0.93
Vibrations for the Whole Body (ISO 2631-1)	m/s ²	0.36	0.36
Gradeability – Manual Transport		16% (9.09°)	16% (9.09°)
Gradeability – Manual Cleaning		9% (5.14°)	9% (5.14°)
Gradeability - Autonomous		2% (1.15°)	2% (1.15°)
Machine Length	inch / cm	66.7 / 169.5	66.7 / 169.5
Machine Height (top of beacon)	inch / cm	55.2 / 140.1	55.2 / 140.1
Machine Width	inch / cm	31.9 / 81.1	32.1 / 81.6
Machine Width with Squeegee	inch / cm	32.6 / 82.9	32.6 / 82.9
Minimum Aisle Turn Width - Manual	inch / m	74 / 1.88	74 / 1.88
Solution Tank Capacity	Gallon / L	26.1 / 99	26.1 / 99
Recovery Tank Capacity	Gallon / L	27.5 / 104	27.5 / 104
Transport Speed – Manual (Fwd. Maximum)	m/sec	1.90	1.90
Transport Speed – Manual (Rev. Maximum)	m/sec	1.24	1.24
Transport Speed – Autonomous (Fwd. Maximum)	m/sec	1.11	1.11
Battery Compartment Size (approximate)			
Height (maximum)	inch / cm	20.9 / 53.3	20.9 / 53.3
Width (maximum)	inch / cm	15.5 / 39.4	15.5 / 39.4
Length (maximum)	inch / cm	25 / 63.5	25 / 63.5
Scrub Brush Size			
Brush / Pad Diameter – Disc (Quantity of 2)	inch / cm	14 / 35.6	-
Scrub Brush Length – Cylindrical (Quantity of 2)	inch / cm	-	27.1 / 68.8
Outside Scrub Brush Diameter – Cylindrical (inside core is Ø x in / x cm)	inch / cm	-	5.75 / 14.6
Scrub Brush Speed	RPM	215-260	900-950
Hopper Capacity - Cylindrical	in ³ / L	-	258 / 4.2
Cleaning Path Width (scrubbing path)	inch / cm	28 / 71.1	28 / 71.1

*Gross Vehicle Weight: Standard machine without options, full solution tank and empty recovery tank, with removable scrub brushes, batteries installed and 165 lb / 75 kg operator.

**Transportation Weight: Standard machine without options, empty solution and recovery tanks, with batteries installed and no operator.

GLOSSARY

<u>Glossary of Terms</u>	
<u>Term</u>	<u>Description</u>
Home Marker	Printed sign with a visual pattern designed for detection by machines. 2D Right Side Camera and BrainOS detection software recognize the Marker. Home Markers identify the set of saved routes available to the machine. 10 unique patterns (ID #'s).
Home Marker Position	Specific point on the map the machine uses to orient itself in the room
Route	Recorded cleaning path, which includes the path the machine will travel and desired scrub settings.
Scan	Machine using it's 2D Right Side Camera to view and identify a Home Marker
AI	Artificial intelligence
BrainOS	Brain operating system navigational software
EULA	End User License Agreement
GPS	Global Positioning System
IMEI	International Mobile Equipment Identity, the ringer equivalence of the built-in modem
LIDAR	Light detection and ranging, used for two of the built-in sensors
LTE	Long-Term Evolution, the built-in modem connection method
ROC	Robotic Operations Center
ROI	Return on investment, the effective value of the machine
SIM	Subscriber Identity Module, used to connect the built-in modem to the wireless carrier
UI	User interface



EU / UE / EL / EC / EE / ES / EÜ / AB

Declaration of Conformity

Prohlášení o shodě
Konformitätserklärung
Overensstemmelseserklæring
Declaración de conformidad
Vastavusdeklaratsioon
Déclaration de conformité
Vaatimustenmukaisuusvakuutus

Декларация за съответствие
Δήλωση συμμόρφωσης
Megfelelősségi nyilatkozat
Izjava o skladnosti
Dichiarazione di conformità
Atitikties deklaracija
Atbilstības deklarācija
Samsvarserklæring
Conformiteitsverklaring

Declaração de conformidade
Deklaracja zgodności
Declaratie de conformitate
Декларация о соответствии
Försäkran om överensstämmelse
Vyhlášení o zhode
Izjava o skladnosti
Uygunluk beyanı

Manufacturer / Výrobce / Hersteller / Fabrikant / Fabricante / Κατασκευαστής /
Gyártó / Proizvođač / Fabbicante / Gamintojas / Ražotājs / Produsent / Fabrikant /
Fabricante / Producent / Producător / производитель / Tillverkaren / Výrobca /
Proizvajalec/ Üretici firma:

**Nilfisk A/S, Kornmarksvej 1
DK-2605 Broendby, DENMARK**

Product / Produkt / Producto, Toode, Produit, Tuote/ Продукт /
Προϊόν / Termék / Proizvod / Prodotto / Produktas / Produkts /
Artikel / Produtos / Produs / Izdelek / Ürün

SC60

Description / Popis / Beschreibung / Beskrivelse / Descripción /
Kirjeldus / La description / Kuvaus / Описание / Περιγραφή / Leirás /
Opis / Descrizione / Aprašymas / Apraksts / Beschrijving / Descrição /
Descriere / Beskrivning / Popis / Açıklama

**FC – Autonomous/rider-type Scrubber – Battery -
Radio enabled
24V DC, IPX4**

- | | | |
|---------------------------------------------------------------------------------------------------------------------------------------------------------------------------|-----------------------------------------------------------------------------------------------------------------------------------------------------------------|---------------------------------------------------------------------------------------------------------------------------------------------------------------------|
| EN We, Nilfisk hereby declare under our sole responsibility, that the above-mentioned product(s) is/are in conformity with the following directives and standards. | BG Ние, Nilfisk С настоящото декларираме на своя лична отговорност, че посочените по-горе продуктът е в съответствие със следните директиви и стандарти. | PT Nós, a Nilfisk declaramos, sob nossa exclusiva responsabilidade, que o produto acima mencionado está em conformidade com as diretrizes e normas a seguir. |
| CS My, Nilfisk prohlašujeme na svou výlučnou odpovědnost, že výše uvedený výrobek je ve shodě s následujícími směrniciemi a normami. | EL Εμείς, Nilfisk δηλώνουμε με αποκλειστική μας ευθύνη, ότι το προαναφερόμενο προϊόν συμμορφώνεται με τις ακόλουθες οδηγίες και πρότυπα. | PL My, Nilfisk Niniejszym oświadczamy z pełną odpowiedzialnością, że wyżej wymieniony produkt jest zgodny z następującymi dyrektywami i normami.. |
| DE Wir, Nilfisk erklären in alleiniger Verantwortung, dass das oben genannte Produkt den folgenden Richtlinien und Normen entspricht. | HU Mi, Nilfisk kijelentjük, egyedüli felelősséggel, hogy a fent említett termék megfelel az alábbi irányelveknek és szabványoknak | RO Noi, Nilfisk Prin prezenta declarăm pe propria răspundere, că produsul mai sus menționat este în conformitate cu următoarele standarde și directive. |
| DA Vi, Nilfisk erklærer hermed under eget ansvar at ovennævnte produkt(er) er i overensstemmelse med følgende direktiver og standarder. | HR Mi, Nilfisk izjavljujemo pod punom odgovornošću, da gore navedeni proizvod u skladu sa sljedećim direktivama i standardima. | RU Мы, Nilfisk настоящим заявляем под нашу полную ответственность, что вышеперечисленные продукция соответствует следующими директивам и стандартам. |
| ES Nosotros, Nilfisk declaramos bajo nuestra única responsabilidad que el producto antes mencionado está en conformidad con las siguientes directivas y normas | IT Noi, Nilfisk dichiara sotto la propria responsabilità, che il prodotto di cui sopra è conforme alle seguenti direttive e norme. | SV Vi Nilfisk förklarar härmed under eget ansvar att ovan nämnda produkt överensstämmer med följande direktiv och normer. |
| ET Meie, Nilfisk Käesolevaga kinnitame ja kanname ainuisikulist vastutust, et eespool nimetatud toode on kooskõlas järgmistele direktiivide ja | LT Mes, „Nilfisk“, prisiimdami visišką atsakomybę pareiškiamo, kad pirmiau minėtas produktas (-ai) atitinka šias direktyvas ir standartus | SK My, Nilfisk prehlasujeme na svoju výlučnú zodpovednosť, že vyššie uvedený výrobok je v zhode s nasledujúcimi smernicami a normami. |
| FR Nilfisk déclare sous notre seule responsabilité que le produit mentionné ci-dessus est conforme aux directives et normes suivantes. | LV Mēs, Nilfisk, ar pilnu atbildību apliecinām, ka iepriekšminētais produkts atbilst šādām direktīvām un standartiem | SL Mi, Nilfisk izjavljamo s polno odgovornostjo, da je zgoraj omenjeni izdelek v skladu z naslednjimi smernicami in standardi. |
| FI Me, Nilfisk täten vakuutamme omalla vastuulla, että edellä mainittu tuote on yhdenmukainen seuraavien direktiivien ja standardien mukaisesti | NO Vi, Nilfisk erklærer herved under eget ansvar, at det ovennevnte produktet er i samsvar med følgende direktiver og standarder | TR Nilfisk, burada yer alan tüm sorumluluklarımızı göze, yukarıda belirtilen ürünüün aşağıdaki direktifler ve standartlara uygun olduğunu beyan ederiz. |
| NL We verklaren Nilfisk hierbij op eigen verantwoordelijkheid, dat het bovengenoemde product voldoet aan de volgende richtlijnen en normen | | |

2006/42/EC	EN 60335-1:2012+A11:2014+A13:2017+A1:2019+A2:2019+A14:2019 EN 60335-2-72:2012
	EN 61000-6-2:2019; EN 55032:2015+A11:2020 EN 301 489-1:V2.2.3; EN 301 489-52 V1.1.0
2000/14/EC – Conformity assessment procedure according to Annex V.	- Measured sound power level: 79 dB(A); Guaranteed sound power level: 82 dB(A)
2014/53/EU	EN 301 908-1 V13.1.1; EN 301 908-2 V11.1.2 EN 301 908-13 V13.1.2

Autonomous aspects are evaluated by TDF #44230-01

Authorized signatory: Pierre Mikaelsson, Executive Vice President, Global Products & Services, Nilfisk NLT

Feb 10, 2021



Nilfisk A/S
Kornmarksvej 1 · DK-2605 Brøndby · Denmark
Tel.: +45 43 23 81 00 · Fax: +45 43 43 77 00
mail.com@nilfisk.com
www.nilfisk.com

